

safetylink™

INSTALLATION HANDBOOK:
**Installation of SafetyLink
Anchor Points**



READ ENTIRE HANDBOOK BEFORE INSTALLING ANY SAFETYLINK PRODUCT.

ALL PRODUCTS MUST BE INSTALLED IN ACCORDANCE WITH SAFETYLINK'S INSTALLATION HANDBOOK, USING ONLY PRODUCTS SUPPLIED BY SAFETYLINK PTY LTD.

**FAILURE TO FOLLOW ALL WARNINGS AND INSTRUCTIONS MAY RESULT
IN A SERIOUS INJURY OR DEATH.**

If you are uncertain and need help please email: safetylink@heightsafety.com.au
Phone: 1300 789 545 | Fax: 1300 738 071
or visit our website www.heightsafety.com

**INSTALLATION HANDBOOK
FOR SAFETYLINK ANCHOR POINTS**

	Page
WARNINGS	3
MAINTENANCE – PERIODIC INSPECTIONS	4
WARRANTIES	5
SAFE LADDER ACCESS	
Fixed LadderLink: Ladder Support Bracket	6-7
TIMBER CONSTRUCTION INSTALLATION	
CableLink.....	8-9
TileLink	10-11
Stainless Steel HingeLink to Timber Rafter	12
Aluminium HingeLink to Timber Rafter	13
RidgeLink to Timber Rafter.....	14
RafterLink to Timber Rafter	15
RafterLink Side Mounted to Timber Rafter	16
Stainless Steel HingeLink to Timber Truss at the top of a ridge.....	17
INSTALLATION TO STEEL PURLINS	
PurLink to Steel Purlins	18
RetroLink – Block to Steel Purlins	19
RetroLink – Tube to Steel Purlins.....	20-21
INSTALLATION TO ROOF SHEET SURFACE	
FrogLink.....	22
Advance SurfaceLink to Roof Sheet - Single Plate	23-26
SurfaceLink to Roof Sheet - Double Plate.....	27-29
INSTALLATION INTO CONCRETE	
WindowLink - a Concealed Eyebolt... ..	30
SwiveLink Anchor	31
ConcreteLink Eyebolt - Concrete Inserts.....	32
ConcreteLink Collared Eyebolt - Concrete Inserts	33
ConcreteLink Eyebolt - Extended	34
INSTALLATION INTO MASONRY	
SpacerLink.....	35
SandwichLink with Spacer.....	36
SandwichLink	37
INSTALLATION ONTO RITECK ROOFING	
SandwichLink Anchor Point.....	38
APPENDIX	
Diagram 1 – Eyebolt Layout	39
Diagram 2 – SafetyLink Anchor Points Positioning Layout	40
Diagram 3 – SafetyLink Anchor Points Positioning Layout	41
Diagram 4 – Lateral Bracing Strap	42
Diagram 5 – Positioning HingeLink	43
Diagram 6 – Strengthening Rafter Plates.....	44
Diagram 7 – HingeLink Unit.....	45
IN CASE OF ACCIDENT	46

WARNINGS

READ CAREFULLY SOMEONE'S LIFE DEPENDS ON IT

The building or structure for the anchorages should be assessed by an engineer, unless it is clear to a competent person that the anchorages system is structurally adequate.

INSTALLATION MUST BE CARRIED OUT BY, OR UNDER THE SUPERVISION OF A COMPETENT PERSON.

SafetyLink Anchors are designed to withstand a drop force of 22.1kN (concrete anchors 15kN)

**STANDARD EYEBOLTS MUST ONLY BE USED AS A FALL ARREST ANCHOR.
ABSEILING EYEBOLTS ARE TO BE USED FOR ROPE ACCESS (ABSEILING).
SURFACE MOUNTED ANCHORS MUST NOT BE USED FOR ROPE ACCESS (ABSEILING).**

When installing anchor points all safety procedures must be complied with in accordance with the current safety code/s of practice/s for working at heights.

- To prevent galling use a spray can of nickel anti-seize.
- Recommended waterproofing for roof tiles: *Sika Flex Co-Polymer Sealant*.
- Recommended waterproofing for metal roof: *Silicone Sealant*.
- All threads must be coated with Loctite prior to assembly. (IMPORTANT NOTE: Before applying Loctite 243 use Loctite 7471 primer to activate the surface according to manufacturer's instructions).

⚠ Maximum user per eyebolt is One (1).

WARNING

Locking Hex Nut must be fully screwed up the thread of the eyebolt to expose 30mm of thread. This thread must be fully screwed into the bracket.

Locking Hex Nut must be firmly tightened onto the bracket to stop the eyebolt from unscrewing and to gain maximum strength.

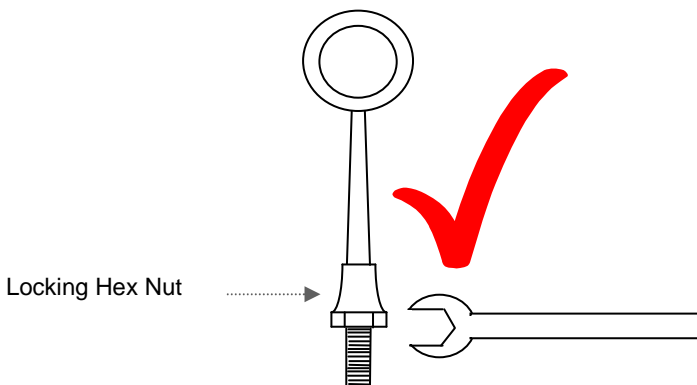
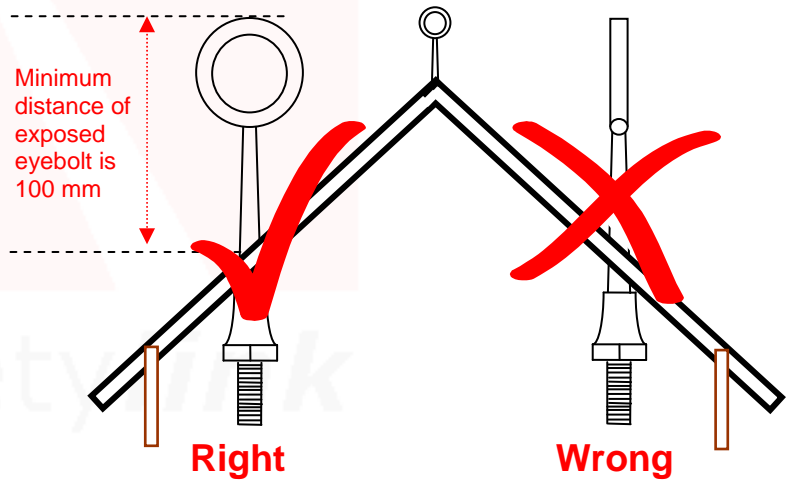
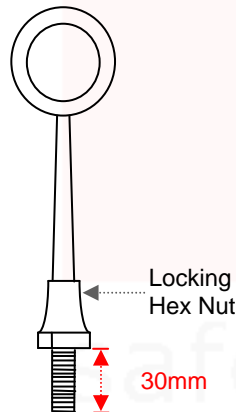

Right

Always use a spanner when tightening and un-tightening the locking hex nut.

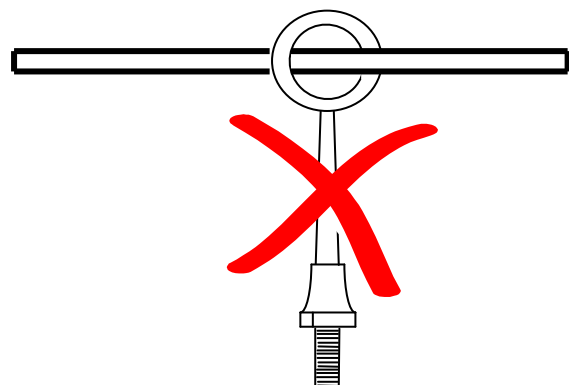

Wrong

Do not place an object into the eye of the eyebolt to tighten or un-tighten the locking hex nut, as this may damage the eyebolt.



MAINTENANCE – PERIODIC INSPECTIONS

All items of equipment which are in regular use shall be subjected to periodic inspection and servicing. These regular scheduled inspections and servicing must be carried out by a competent person. (refer to AS/NZS 1891.4:2000 section 9 if clarification required or contact us).

Fixed LadderLink: Ladder Support Bracket

ALL LADDERLINKS MUST BE INSPECTED EVERY 12 MONTHS, INSPECTIONS NEED TO BE CARRIED OUT BY A COMPETENT PERSON.

Procedures to be followed at inspection time:

- Visually inspect ladder support brackets for any signs of deterioration or the protective coating being removed. (Note: LadderLink is made from marine grade aluminium and therefore should not corrode).
- Ensure LadderLink is firmly secured to the structure as per SafetyLink Installation Handbook. (refer to Installing LadderLink Page 5).

SafetyLink Anchorages

(In accordance with AS/NZS 1891.4:2000 clause 9.3.3)

ALL ANCHORAGES MUST BE INSPECTED EVERY TWELVE MONTHS, INSPECTIONS NEED TO BE CARRIED OUT BY A COMPETENT PERSON.

Procedures to be followed at inspection time:

- Visually inspect anchors for signs of deterioration.
- The FrogLink/TileLink anchor point has two energy absorbing regions and two stabilising joints which hold the eyelet in place during use. If these energy absorbing regions are expanded this will indicate the anchor point has arrested a fall. Similarly if the two stabilising joints have been broken this would also indicate the FrogLink/TileLink has arrested a fall and should be replaced.
- Visually inspect the CableLink anchor point for signs that it has arrested a fall. The cable will have tightened around the rafter and the bottom fixing point will be pulled out and the anchor will need to be replaced.
- The eyebolt should remain straight, a bent eyebolt will indicate that the anchor point has arrested a fall (The design features of the eyebolt includes the ability to bend like a fishing pole starting from the top and working its way to the bottom, enabling it to use up energy as the eyebolt bends whilst lessening the force on the person falling and the attachment point).
- Visually inspect the components of the anchor for corrosion, superficial surface marking is permitted while deeper corrosion or pitting would require attention.
- Manually (by hand) check the eyebolt for rigidity and tightness, if the eyebolt can turn in the anticlockwise direction it will require attention.
- Visually inspect the rubber hat washer and waterproofing components to ensure it has remained sealed.
- Visually inspect the attachment component of the anchorage where practically possible.
- Visually inspect the parent structure for modifications or deterioration which might lead to loss of anchorage strength.
- Drilled in anchorages such as friction or glued-in anchorages (ConcreteLink, SandwichLink, SpacerLink) must be proof tested in accordance with AS/NZS 1891.4:2000 Clause 3.1.2(g) as part of each inspection.

IN ADDITION TO SAFETYLINK PTY LTD EQUIPMENT, ALL ANCILLARY EQUIPMENT MUST BE INSPECTED IN ACCORDANCE WITH AS/NZS 1891.4:2000 AND THE MANUFACTURER'S INSTRUCTIONS.

⚠ FOR MAINTENANCE ADVICE AND SERVICES PLEASE CONTACT SAFETYLINK ON 0249 972272 OR 1800 972272 FOR YOUR NEAREST SAFETYLINK INSPECTION SERVICE CENTRE OR EMAIL: safetylink@heightsafety.com.au

To download Installation Manuals on other SafetyLink products please visit our Website at www.heightsafety.com

EXTRACT: SafetyLink Pty Ltd STANDARD TERMS AND CONDITIONS

- 11.1 To the extent permitted by law all implied conditions, warranties and undertakings are expressly excluded.
- 11.2 Except as provided in this clause the Company shall not be liable for any loss or damage, whether direct or indirect (including consequential losses or damage) arising out of any breach of contract by the Company or any negligence of the Company, its employees or agents.
- 11.3 Should the Company be liable for a breach of a condition or warranty implied by Division 2 Part V of the Trade Practices Act 1974 (not being a condition or warranty implied by Section 69 of that Act) then its liability for a breach of any such condition or warranty express or implied shall be limited, at its option, to any one or more of the following.
- A) in case of Goods
- (I) the replacement of the Goods or the supply of equivalent Goods.
 - (II) the repair of the goods,
 - (III) the payment of the cost of replacing the Goods or acquiring equivalent Goods.
 - (IV) The payment of the cost of having the Goods repaired.
 - (V) Provided that any such Goods are returned to the Company by the Purchaser at the Purchaser's expense.
- B) in the case of services
- (i) the supply of the services again,
 - (ii) the payment of the cost of having the services supplies again.
- 11.4 The Company will not be liable for the costs of recovery of the Goods from the field, loss of use of the Goods, loss of time, inconvenience, incidental or consequential loss or damage, nor for any other loss or damage of her than as stated above, whether ordinary or exemplary, caused either directly or indirectly by use of the Goods.
- 11.5 The Company warrants that at the time of shipment, Products manufactured by it will be free from defects in material and workmanship. In the absence of a modified written warranty, the Company agrees to making good any such defects by repairing the same or at the Company's option by replacement, for a period of (1) one year from the date of shipment. This limited warranty applies provided that:
- (a) defects have arising solely from faulty materials or workmanship;
 - (b) the Products have not received maltreatment, inattention or interference;
 - (c) **the Products have been installed in accordance with the Company's Installation Handbooks using only products supplied by the Company;**
 - (d) accessories used with the Products are manufactured by or approved by the Company;
 - (e) the Products are maintained in accordance with Australian Standard 1891.4 (section 9).

This warranty does not apply to any defects or other malfunctions caused to the Goods by accident, neglect, vandalism, misuse, alteration, modification or unusual physical, environment or electrical stress.

- 11.6 If any goods are not manufactured by the Company, the guarantee of the manufacturer thereof shall be accepted by the Purchaser as the only express warranty given in respect of the goods.
- 11.7 Except as provided in this clause 11, all express and implied warranties, guarantees and conditions under statute or general law as the merchantability, description, quality, suitability or fitness of the Products for any purpose or as to design, assembly, installation, materials or workmanship or otherwise are hereby expressly excluded (to the extent to which they may be excluded by law).

PLEASE SEE SAFETYLINK PTY LTD FULL STANDARD TERMS OF CONDITIONS OF SALE FOR FURTHER REFERENCE.



FIXED LADDERLINK – LADDER SUPPORT BRACKET

Product Code: LADFX001

INSTALLATION:

All safety procedures must be complied with in accordance with the current legislation and regulations. Ensure safety at all times by being attached to anchor point approved safety equipment, using a scaffold or a secured ladder.

Fixed LadderLink: Safe Ladder Access

Made from marine grade aluminium the LadderLink is designed to support a ladder, stopping sideways movement and therefore holding the ladder in place safely. In addition the LadderLink has securing points to tie off the ladder providing a safe access point.

To install the LadderLink simply place under the roof sheeting or tiles and secure to the top of a rafter and roof batten as shown in the drawings below.

- ⚠ Adjust the pitch of the LadderLink using a SAFETYLINK LADDERLINK BENDER ONLY. LadderLink is made from high tensile aluminium therefore use of a standard folder may crack the aluminium.
- ⚠ Protective coating must not be removed.

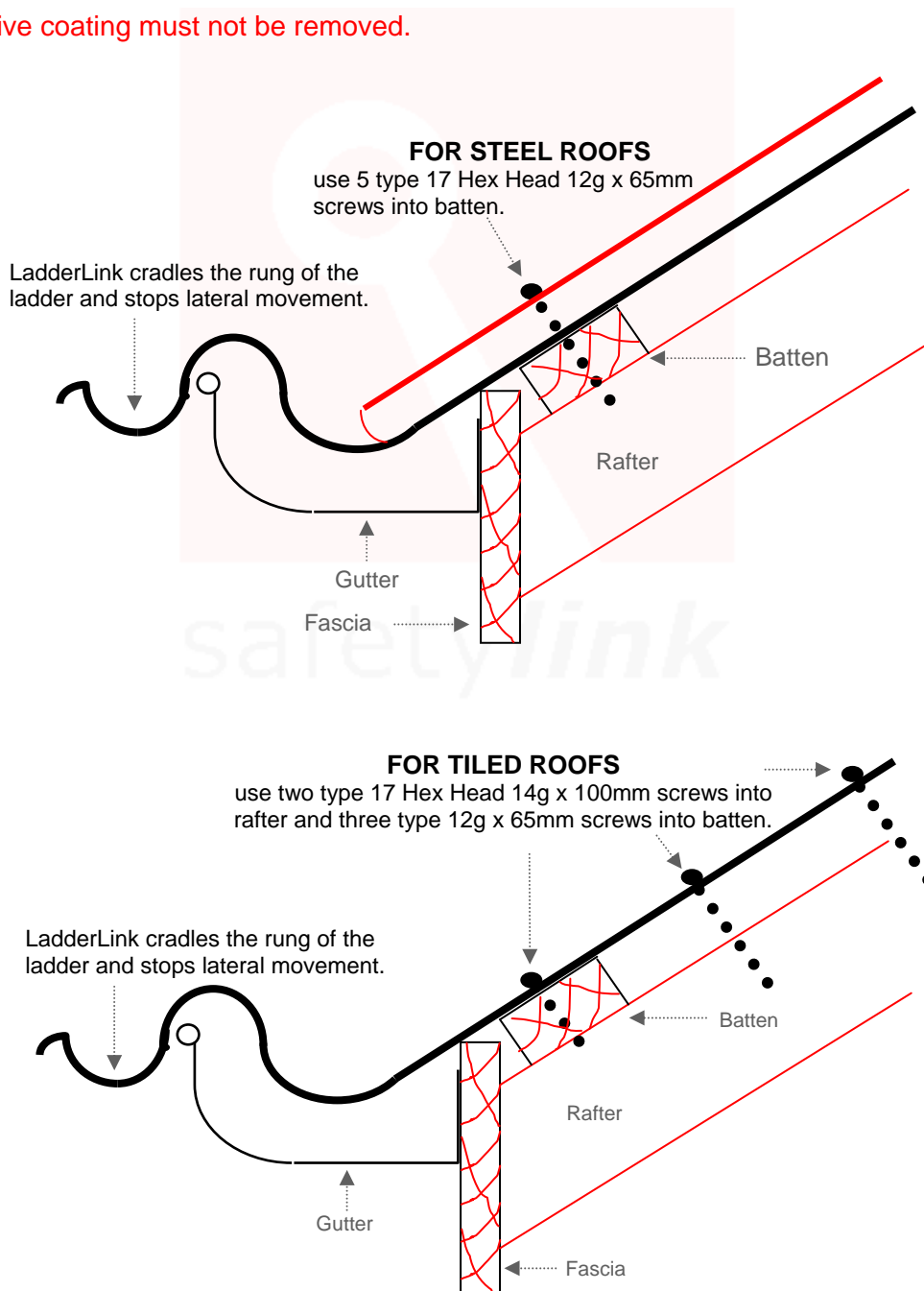



FIXED LADDERLINK – LADDER SUPPORT BRACKET

Product Code: LADFX003

FIXING TO CONCRETE WALL/PARAPET

Drill and install 4 (four) x 10mm Dyna bolts or equivalent chemical anchor. Bolts need to be a minimum of 150mm from an edge.

FIXING TO TIMBER WALL/PARAPET

Drill and install 4 (four) x size 14-10 x 75mm roofing screws.

LadderLink cradles the rung of the ladder and stops lateral movement.

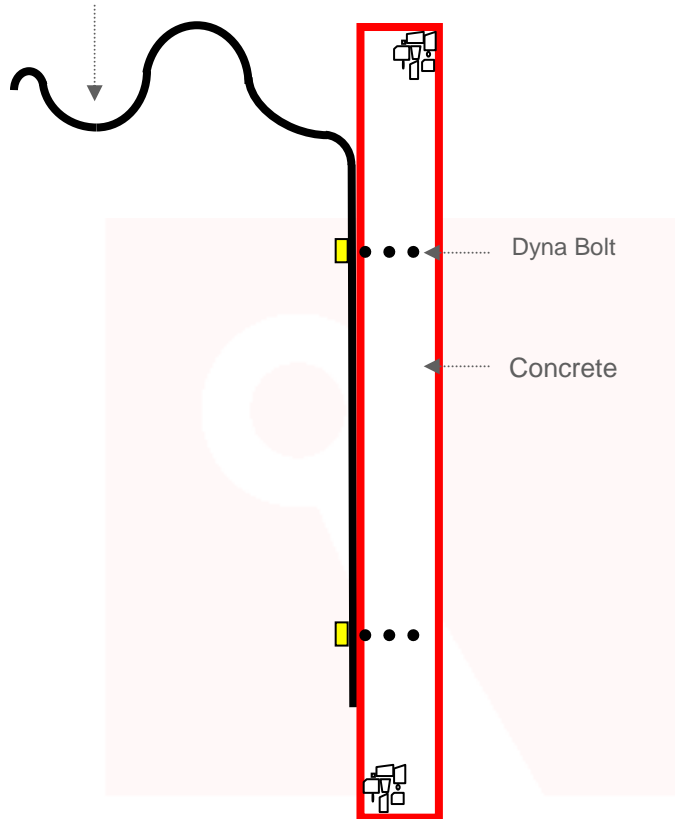

safetylink

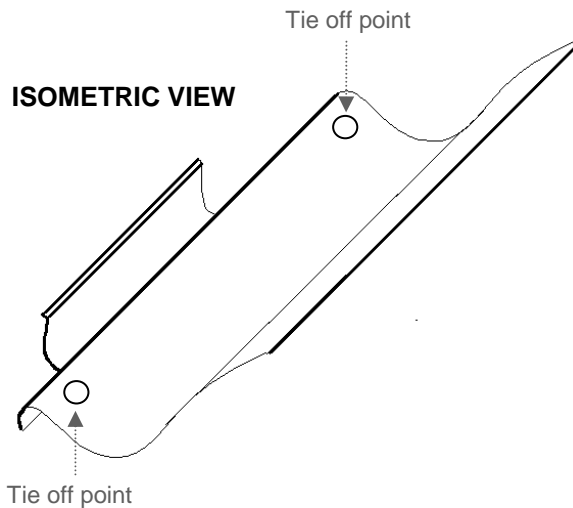

INSTALLATION: TO A TIMBER RAFTER - EXISTING BUILDING

⚠ CABLELINK ANCHORS MUST NOT BE USED FOR ROPE ACCESS (ABSEILING).

All safety procedures must be complied with in accordance with the current safety code(s) of practice(s) for working at heights. Ensure safety at all times by being attached to anchor point approved safety equipment, using a scaffold or a secured ladder.

Positioning of CableLink Anchor Point *(refer to appendix diagrams 2 and 3)*

The first CableLink anchor point must be in a position easily reached by a secured ladder or a manhole access point.

Inspect the timber for strength

1. Inspect the timber for splits, cracks, knots, white ant damage and inspect the timber to make sure it is secured to the structure.
2. Minimum timber size is 35mm by 90mm (grade F5).
3. Attach anchors only to timber strong enough to support the anchor point.



⚠ If any doubt exists as to the strength of the structure an engineer should make the assessment.

⚠ During installation you must be safe at all times.

⚠ Installation must be carried out by, or under the supervision of a competent person.

COMPONENTS:

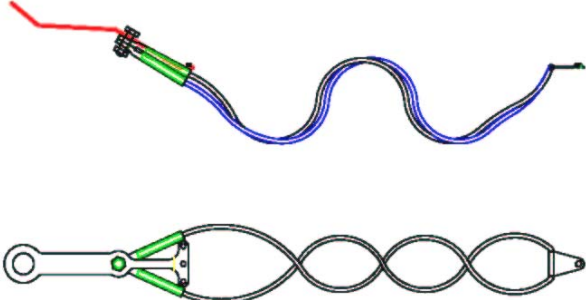
- 1 x CableLink Anchor Plate
- 1 x Cable with Swaged Ends & Top Fixing Point
- 1 x Bolt: 12mm
- 1 x Nut: 12mm Nylon Locking Nut

<p>CableLink Anchor Plate</p>	
<p>Cable with Swaged Ends & Top Fixing Point</p>	
<p>Bolt: 12mm & Nut: 12mm Nylon Locking Nut</p>	

INSTALLATION: TO A TIMBER RAFTER - EXISTING BUILDING

Fitting the anchor point

Before installation adjust the plate to suit the profile of the roof.

The anchor plate also has 3 alternative fixing holes. Choose one hole only to secure the plate to the top of the rafter to suit the pattern of the tiles.

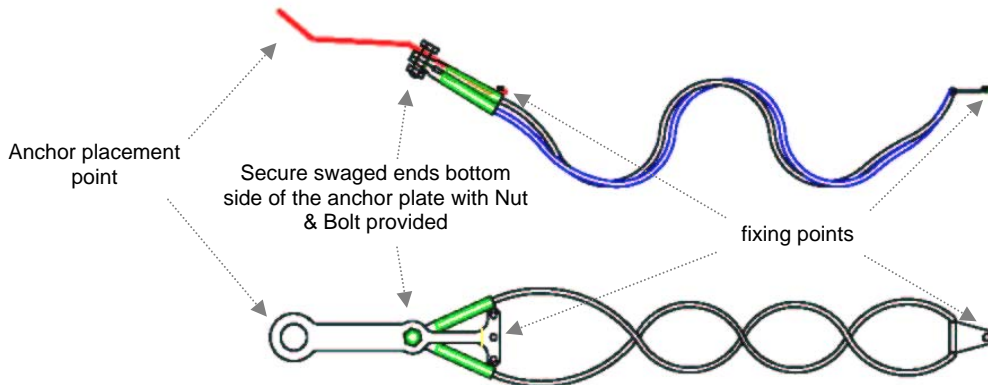

Installation of the CableLink

1. Remove the roof tiles to expose the rafters. If there is sarking under the roof tiles cut slots on either side of the rafters to thread the Cable component through.
2. Lay the centre of the cable approximately 400mm up from the anchor plate placement point. Take each end of the cable and cross them underneath the rafter twice. Bring the ends of the cable up either side of the rafter.
3. Secure the ends and the anchor plate together with the 12mm Bolt and Nylon Locking Nut supplied. Put the bolt through the plate first then the two cable ends. FINGER TIGHT ONLY. (Secure Bolt/Nut/ Anchor plate firmly at end of installation).
4. Screw the anchor plate onto the top of the rafter using one of the holes in the bottom fixing point where it is suitable to fit the tile pattern (use 12 gauge roofing screws).
5. Take the top fixing point on the cable and pull the cable up the rafter firmly.
6. Screw the top fixing point on the cable to the top of the rafter (use 12 gauge roofing screws).
7. Tighten the bolt and nut connecting the cable to the anchor plate.
8. Pump silicone between the anchor plate and the bottom tile.
9. Put more silicone onto the top of the anchor plate and also on the bottom tile on either side of the anchor plate.
10. Place the top tile into position sandwiching the anchor point.
11. Re nail the top tile back into place.
12. Replace all removed roof tiles back into their original position.

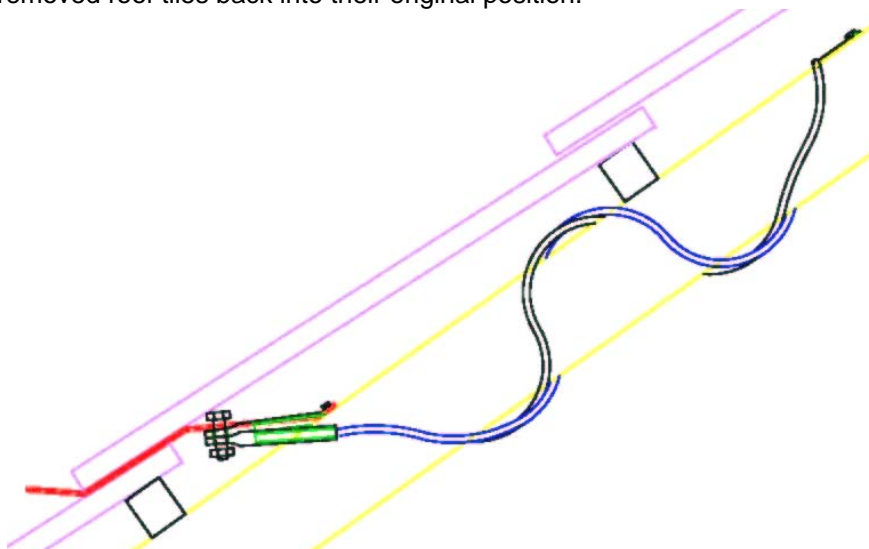

The SafetyLink anchor point is now ready for use, giving you an anchor point to attach to while installing the next SafetyLink.

INSTALLATION: TO A TIMBER RAFTER - EXISTING BUILDING

⚠ TILELINK ANCHORS MUST NOT BE USED FOR ROPE ACCESS (ABSEILING).

All safety procedures must be complied with in accordance with the current safety code(s) of practice(s) for working at heights. Ensure safety at all times by being attached to anchor point approved safety equipment, using a scaffold or a secured ladder.

Positioning of TileLink Anchor Point *(refer to appendix diagrams 2 and 3)*

The first TileLink anchor point must be in a position easily reached by a secured ladder or a manhole access point.

Inspect the timber for strength

1. Inspect the timber for splits, cracks, knots, white ant damage and inspect the timber to make sure it is secured to the structure.
2. Minimum timber size is 35mm by 90mm (grade F5).
3. Attach anchors only to timber strong enough to support the anchor point.

⚠ If any doubt exists as to the strength of the structure an engineer should make the assessment.

⚠ During installation you must be safe at all times.

⚠ Installation must be carried out by, or under the supervision of a competent person.

COMPONENTS:

1 x TileLink Anchor Plate

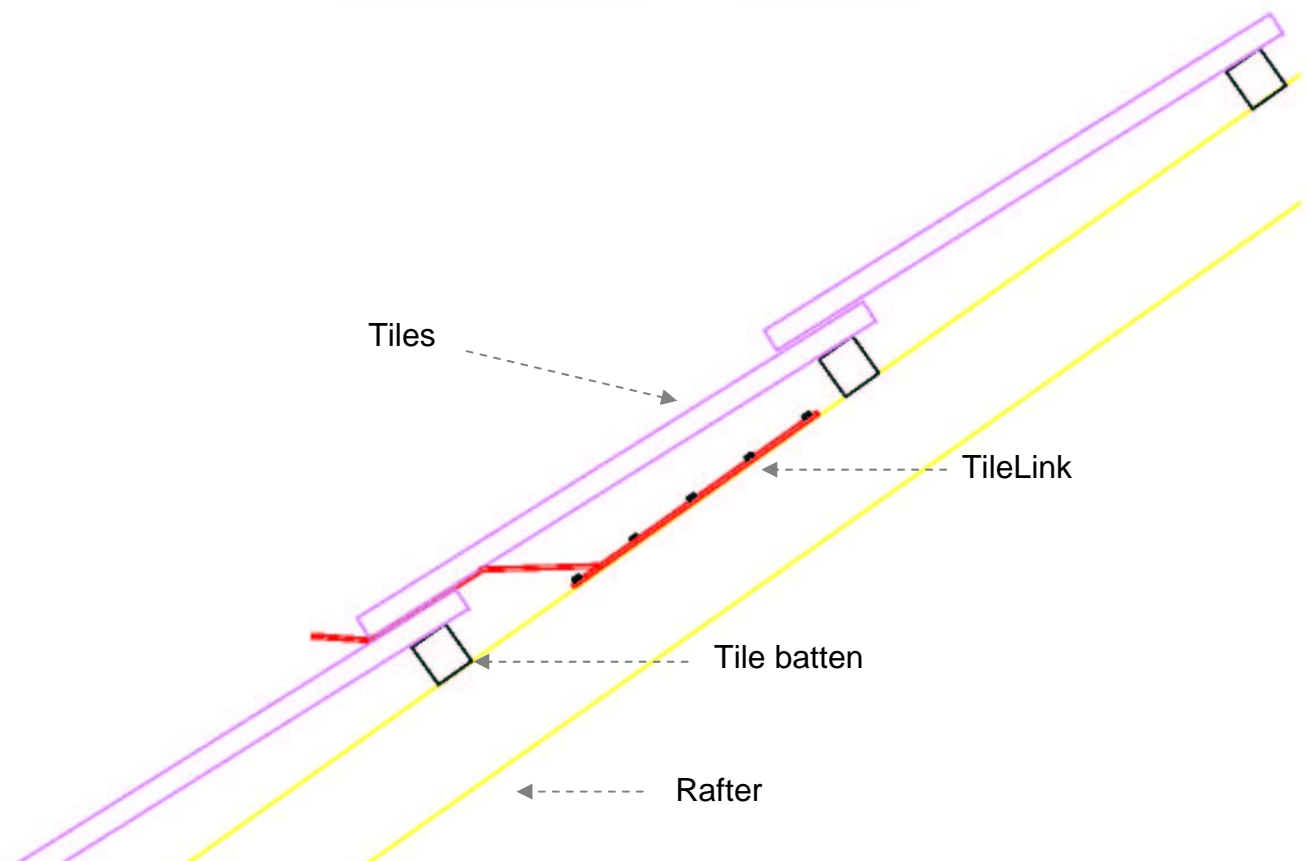
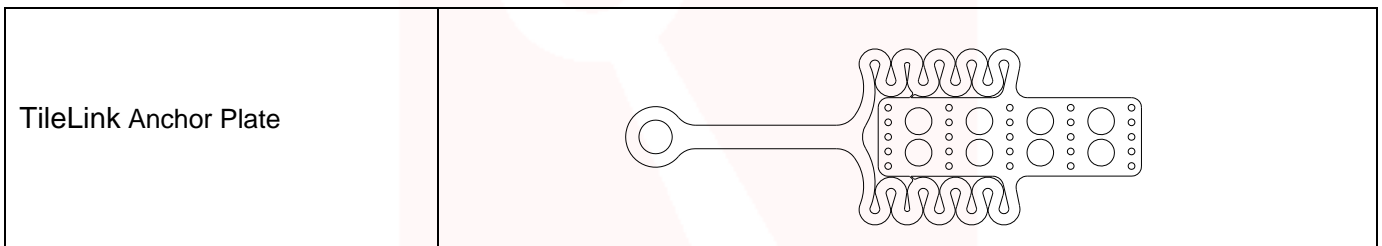



INSTALLATION: TO A TIMBER RAFTER - EXISTING BUILDING

Fitting the anchor point

Before installation adjust the plate to suit the profile of the roof.

The anchor plate also has 5 alternative fixing lines. Choose one line only to secure the plate to the top of the rafter to suit the pattern of the tiles.

TileLink is to be secured using five (5) fixing points.
There are five (5) alternate rows to choose to suit the tile profile,
three examples illustrated below:

NOTE: MAKE SURE ONE LINE OF THE FIXING HOLES IS IN LINE WITH THE CENTRE OF THE RAFTER.

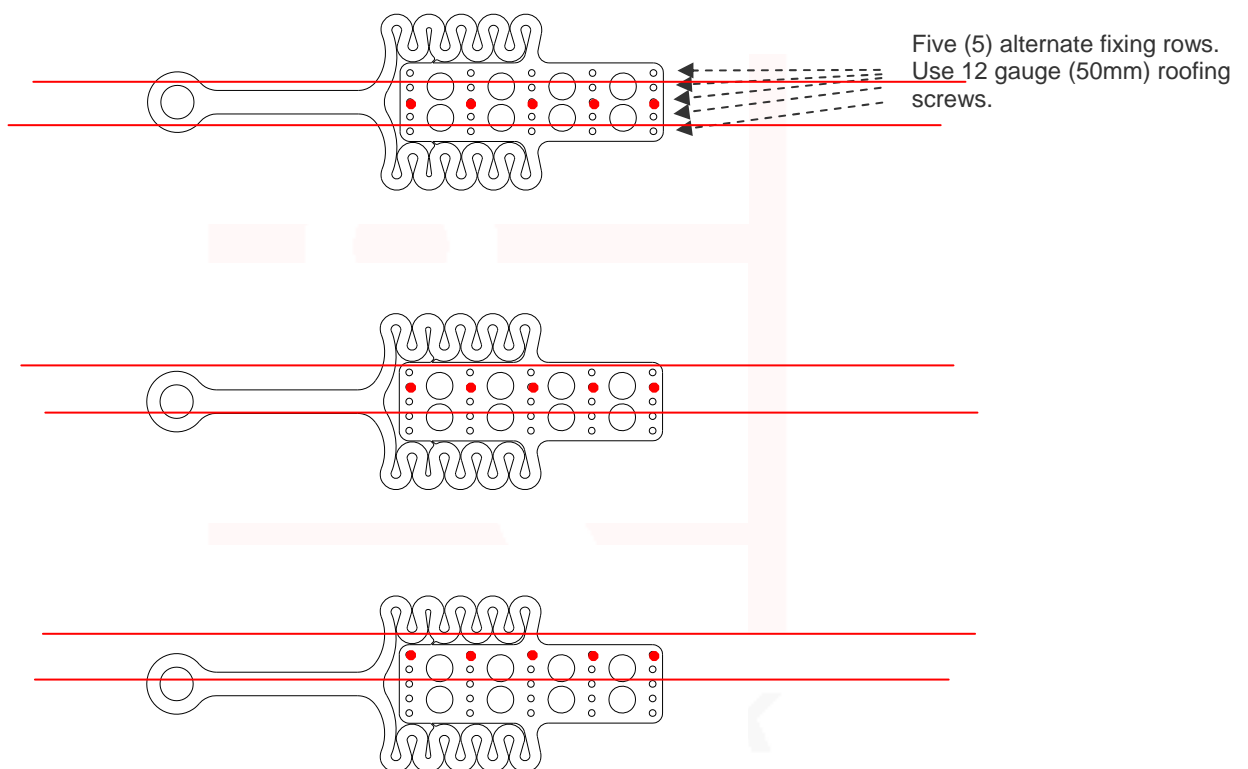

Installation of the TileLink

1. Remove the roof tiles in desired location to expose the rafter.
2. Place TileLink in position to best suit tile pattern, making sure **one line of the fixing holes lines up with the centre of the rafter.**
3. Pump silicone between the anchor plate and the bottom tile.
4. Secure TileLink plate to the rafter using five (5) x 12 gauge (50mm) roofing screws.
5. Put more silicone onto the top of the anchor plate and also on the bottom tile on either side of the anchor plate and also across the bottom tile affectively gluing the bottom tile to the top tile.
6. Place the top tile into position sandwiching the anchor point.
7. Re nail the top tile back into place.
8. Replace all removed roof tiles back into their original position.

The SafetyLink anchor point is now ready for use, giving you an anchor point to attach to while installing the next SafetyLink.



INSTALLATION: TO THE SIDE OF A TIMBER RAFTER - EXISTING BUILDING

All safety procedures must be complied with in accordance with the current safety code(s) of practice(s) for working at heights. Ensure safety at all times by being attached to anchor point approved safety equipment, using a scaffold or a secured ladder.

Positioning of HingeLink Anchor Point (refer to appendix diagrams 2 and 3)

The first HingeLink anchor point must be in a position easily reached by a secured ladder or a manhole access point.

Inspect the timber for strength

1. Inspect the timber for splits, cracks, knots, white ant damage and inspect the timber to make sure it is secured to the structure.
2. Minimum timber size is 35mm by 90mm (grade F5).
3. Attach anchors only to timber strong enough to support the anchor point.

⚠ If any doubt exists as to the strength of the structure an engineer should make the assessment.

Fixing Stainless Steel HingeLink Bracket

1. **Tip:** Place the bracket in centre of rafter, 80mm down from the under side of the roof sheeting, mark the centre of hole for the eyebolt and the bolt holes in the bracket.
2. Use markings to drill required holes.
3. To secure the bracket use 4 type 12mm steel bolts with washers under the nut (coat threads with Loctite).
4. Use 2 Hex Head 12g 40mm screws in the small holes.

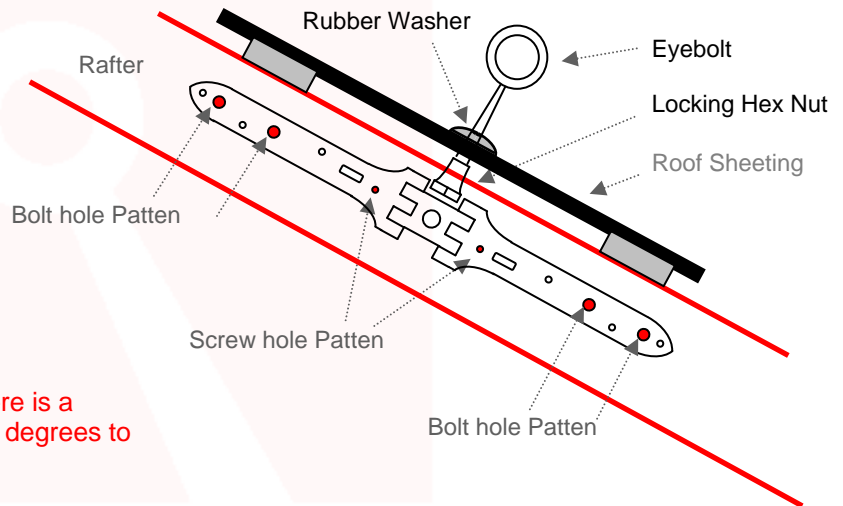

⚠ Lateral bracing straps must be used if there is a possibility of falling in a direction 45 to 90 degrees to the rafter (refer to appendix diagram 4).

Installing the SafetyLink Stainless Steel Eyebolt

1. This requires one installer on the top of the roof sheeting and the other under the roof sheeting.
2. To stay safe while installing the first anchor point the eyebolt should be positioned so you can reach it off a secured ladder or access point. **⚠** During installation you must be safe at all times.
3. The person on the roof makes sure the rubber washer is on the eyebolt before placing the eyebolt through the 16mm hole.
4. The person underside of the roof screws the locking hex nut fully onto the eyebolt exposing 30mm of thread, coat threads with Loctite (IMPORTANT NOTE: Before applying Loctite 243 use Loctite 7471 primer to activate the surface according to manufacturer's instructions). (refer to appendix diagram 1).
5. The person on the roof is now ready to screw the eyebolt all the way into the HingeLink Hinged Bracket.
6. Before tightening the locking hex nut turn the eyebolt to line up with the fall of the roof (refer to appendix diagram 1).
7. The person underside of the roof tightens the locking hex nut using a spanner.

Threads need to have a minimum of **six full 360° turns** into the ultimate thread.

Note: use the same procedure to install a SafetyLink Abseiling Eyebolt, SafetyLink Intermediate T Bolt, SafetyLink End Anchor Taper Bolt.

Waterproofing (apply only to a dry surface)

The person on the roof uses a sealant between the rubber hat washer and the roof sheeting to waterproof the roof.

The SafetyLink anchor point is now ready for use, giving you an anchor point to attach to while installing the next SafetyLink.



INSTALLATION: TO THE SIDE OF A TIMBER RAFTER - EXISTING BUILDING

All safety procedures must be complied with in accordance with the current safety code(s) of practice(s) for working at heights. Ensure safety at all times by being attached to anchor point approved safety equipment, using a scaffold or a secured ladder.

Positioning of HingeLink Anchor Point (refer to appendix diagrams 2 and 3)

The first HingeLink anchor point must be in a position easily reached by a secured ladder or a manhole access point.

Inspect the timber for strength

1. Inspect the timber for splits, cracks, knots, white ant damage and inspect the timber to make sure it is secured to the structure.
2. Minimum timber size is 35mm by 90mm (grade F5).
3. Attach anchors only to timber strong enough to support the anchor point.

⚠ If any doubt exists as to the strength of the structure an engineer should make the assessment.

Fixing steel plates

Fix 2 steel plates to the timber rafter (1 for either side) flush with the top of the rafter or 80mm down from under side of roof sheeting to the top of the steel plate, hold in place with 2.8g x 30 mm galvanized clouts or screws (refer to appendix diagrams 4 and 5).

Fixing Aluminium HingeLink Bracket

1. **Tip:** Place the bracket in centre of the steel plate, 80mm down from the under side of the roof sheeting and mark the centre of hole for the eyebolt and the bolt holes in the bracket.
2. Use markings to drill required holes.
3. To secure the bracket use 8 type 8mm mild steel bolts with washers under the nut (coat threads with Locktite).

⚠ Lateral bracing straps must be used if there is a possibility of falling in a direction 45 to 90 degrees to the rafter (refer to appendix diagram 4).

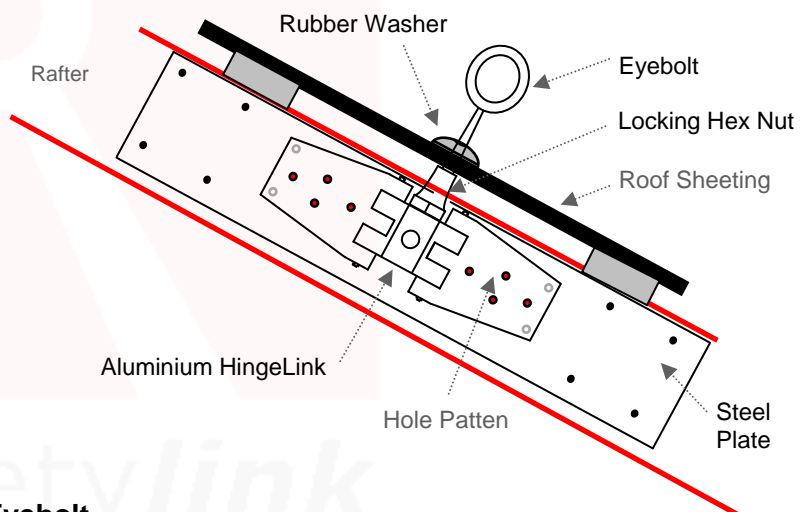

Installing the SafetyLink Stainless Steel Eyebolt

1. This requires one installer on the top of the roof sheeting and the other under the roof sheeting.
2. To stay safe while installing the first anchor point the eyebolt should be positioned so you can reach it off a secured ladder or access point. **⚠** During installation you must be safe at all times.
3. The person on the roof makes sure the rubber washer is on the eyebolt before placing the eyebolt through the 16mm hole.
4. The person underside of the roof screws the locking hex nut fully onto the eyebolt exposing 30mm of thread, coat threads with Loctite (IMPORTANT NOTE: Before applying Loctite 243 use Loctite 7471 primer to activate the surface according to manufacturer's instructions).
5. The person on the roof is now ready to screw the eyebolt all the way into the HingeLink Hinged Bracket.
6. Before tightening the locking hex nut turn the eyebolt to line up with the fall of the roof (refer to appendix diagram 1).
7. The person underside of the roof tightens the locking hex nut using a spanner.

Note: use the same procedure to install a SafetyLink Abseiling Eyebolt, SafetyLink Intermediate T Bolt, SafetyLink End Anchor Taper Bolt.

Waterproofing (apply only to a dry surface)

The person on the roof uses a sealant between the rubber hat washer and the roof sheeting to waterproof the roof.

The SafetyLink anchor point is now ready for use, giving you an anchor point to attach to while installing the next SafetyLink.

INSTALLATION: ATTACHED TO RAFTERS AT THE TOP OF A RIDGE

All safety procedures must be complied with in accordance with the current safety code(s) of practice(s) for working at heights. Ensure safety at all times by being attached to anchor point approved safety equipment, using a scaffold or a secured ladder.

Positioning of RidgeLink Anchor Point (refer to appendix diagrams 2 and 3)

The first RidgeLink anchor point must be in a position easily reached by a secured ladder or a manhole access area.

Inspect the timber for strength

- Inspect the timber for splits, cracks, knots, white ant damage and inspect the timber to make sure it is secured to the structure.
- Minimum timber size is 35mm by 90mm (grade F5).
- Attach anchors only to timber strong enough to support the anchor point.

⚠ If any doubt exists as to the strength of the structure an engineer should make the assessment.

Fixing RidgeLink

1. Fixing to hardwood F14 or greater, use 8 type 17 hex head 14g x 75mm screws.
2. Fixing to softwood less than F14, use 8 type 17 hex head 14g x 90mm screws.
3. Placing the eyebolt in the bracket makes it easier to check the eyebolt for plumb.
4. Place the bracket across the ridge and down the two opposing rafters, make sure the eyebolt is plumb then mark the holes (refer to appendix diagram 4).
5. **4.5mm pilot holes must be drilled into the timber the full length of each screw** to avoid splitting the timber.
6. Drilling a hole close to the edge of the timber, the hole should be slightly angled inward from the edge giving the screw a stronger hold.
7. To stay safe while installing the first anchor point the eyebolt should be positioned so you can reach it off a secured ladder or scaffold.

Fixing the SafetyLink Stainless Steel Eyebolt

1. When screwing the locking hex nut onto the eyebolt make sure it is fully screwed up exposing 30mm of thread, coat threads with Loctite (IMPORTANT NOTE: Before applying Loctite 243 use Loctite 7471 primer to activate the surface according to manufacturer's instructions).
2. Place the Lateral bracing strap along the ridge and screw the stainless steel eyebolt through the strap and into the stainless steel bracket and tighten the locking hex nut using a spanner (refer appendix diagram 1).
3. Then screw the strap down onto the ridge giving the bracket lateral strength (refer appendix diagram 4).

Note: use same procedure to install a SafetyLink Abseiling Eyebolt or a SafetyLink Intermediate T Bolt.

Relocating the eyebolts during the installation of the roof

You must be safely attached to an anchor point or using an alternative form of roof safety while removing and replacing the eyebolts. Use a spanner to release the locking hex nut then unscrew the eyebolt.

Marking the hole in the roof

Measure the position using two reference points and drill a 16mm hole. For a metal roof simply screw a marker pin into the bracket and lay the sheet or ridge in position and push down on the roof sheet. The pin should mark the position of the 16mm hole to be drilled.

Ready to replace the eyebolt

1. The rubber washer should be on the eyebolt., place the eyebolt through the 16mm hole and screw the locking hex nut onto the eyebolt exposing 30mm of thread (refer to appendix diagram 1).
2. Then screw the eyebolt all the way into the stainless steel bracket (coat threads with Locktite).
3. Before tightening the locking hex nut turn the eyebolt to line up with the fall of the roof (refer to appendix diagram 1).
4. Tighten the locking hex nut using a spanner.

Waterproofing (apply only to a dry surface)

Use a sealant between the rubber washer and the roof sheeting to waterproof the roof. The anchor point is now ready for use.

⚠ Lateral bracing straps must be used if there is a possibility of falling in a direction 45 to 90 degrees to the rafter (Refer to appendix diagram 4).

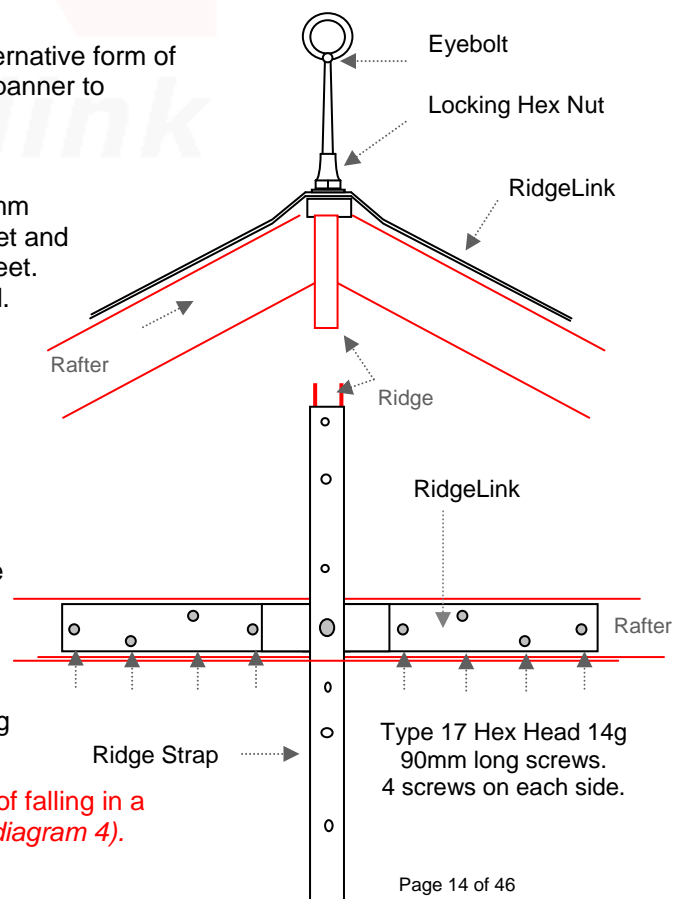

INSTALLATION: ATTACHED TO TIMBER RAFTERS

All safety procedures must be complied with in accordance with the current safety code(s) of practice(s) for working at heights. Ensure safety at all times by being attached to anchor point approved safety equipment, using a scaffold or a secured ladder.

Positioning of RafterLink Anchor Point (refer to appendix diagrams 2 and 3)

The first RafterLink anchor point must be in a position easily reached by a secured ladder or a manhole access area.

Inspect the timber for strength

1. Inspect the timber for splits, cracks, knots, white ant damage and inspect the timber to make sure it is secured to the structure.
2. Minimum timber size is 35mm by 90mm (grade F5).
3. Attach anchors only to timber strong enough to support the anchor point.
 - ⚠ If any doubt exists as to the strength of the structure an engineer should make the assessment.

Fixing RafterLink

1. Fixing to hardwood F14 or greater use 8 type 17 Hex Head 14g x 75mm screws.
2. Fixing to softwood less than F14, use 8 type 17 Hex Head 14g x 90mm screws.
3. **4.5mm pilot holes must be drilled into the timber the full length of each screw** to avoid timber splitting.
4. Drilling a hole close to edge of timber, the hole should be slightly angled inward from the edge giving the screw a stronger hold.

Fixing the SafetyLink Stainless Steel Eyebolt

1. When screwing the locking hex nut onto the eyebolt make sure it is fully screwed up exposing 30mm of thread, coat threads with Loctite (IMPORTANT NOTE: Before applying Loctite 243 use Loctite 7471 primer to activate the surface according to manufacturer's instructions).
2. Place the Lateral Bracing Strap across the rafters and screw the eyebolt through the strap and into the RafterLink and tighten the locking hex nut using a spanner (refer to appendix diagram 1), then screw the Lateral bracing strap down onto the adjacent rafters.
3. The strength of the lateral bracing needed depends on the structure and the amount of risk of a lateral fall off the roof but if any doubt exists as to the strength of the structure an engineer should make the assessment.

Note: use the same procedure to install a SafetyLink abseiling eyebolt or a SafetyLink Intermediate T Bolt.

Relocating the eyebolts during the installation of the roof

You must be safely attached to an anchor point or using an alternative form of roof safety while removing and replacing the eyebolts. Use a spanner to release the locking hex nut then unscrew the eyebolt.

Marking the hole in the roof

Measure the position using two reference points and drill a 16mm hole. For a metal roof simply screw a marker pin into the RafterLink and lay the roof sheet in position and push down on the roof sheet. The pin should mark the position of the 16mm hole to be drilled.

Ready to replace the eyebolt

1. The rubber washer should be on the eyebolt.
2. Place the eyebolt through the 16mm hole and Screw the locking hex nut onto the eyebolt exposing 30mm of thread, coat threads with Loctite (IMPORTANT NOTE: Before applying Loctite 243 use Loctite 7471 primer to activate the surface according to manufacturer's instructions). (refer to appendix diagram 1).
3. Screw the eyebolt all the way into the stainless steel bracket.
4. Before tightening the locking hex nut turn the eyebolt to line up with the fall of the roof. Tighten the locking hex nut using a spanner.

Threads need to have a minimum of six full 360° turns into the ultimate thread.

Waterproofing (apply only to a dry surface)

Use a sealant between the rubber washer and roof sheeting to waterproof the roof.

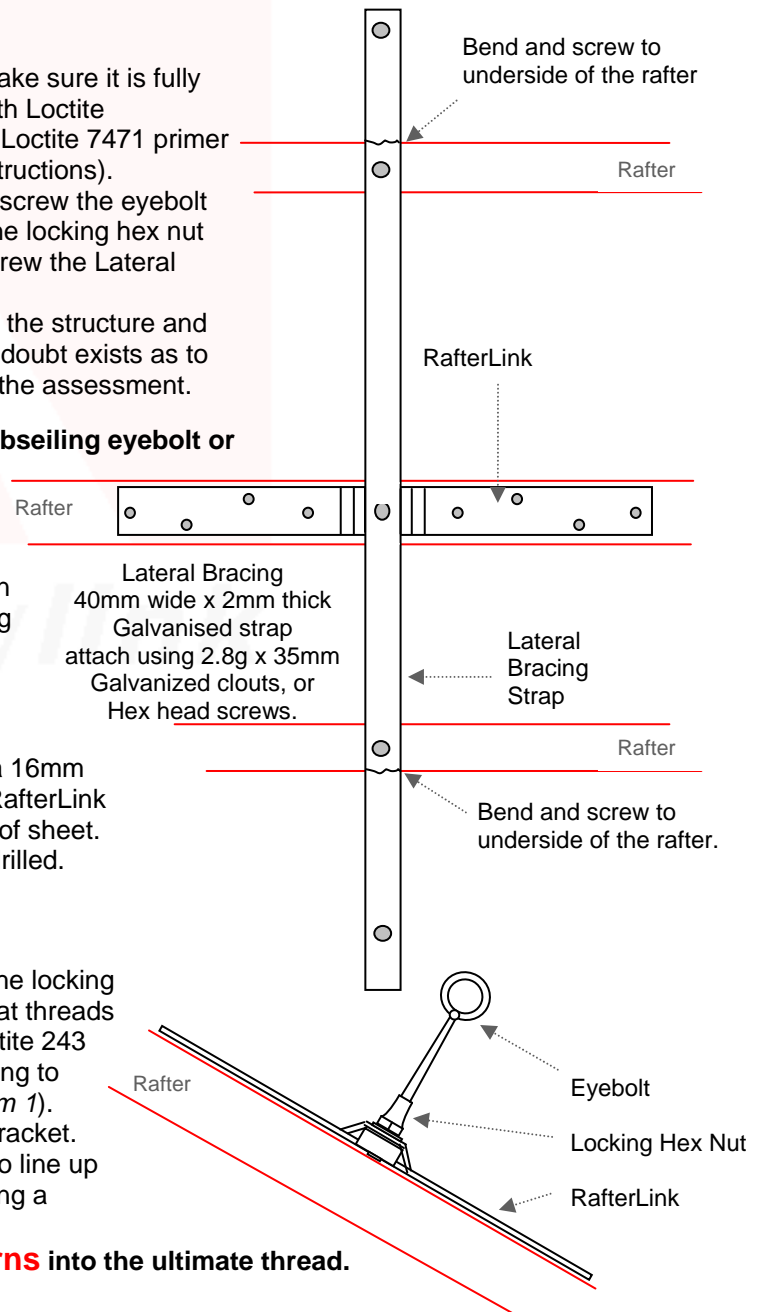

INSTALLATION: TO THE SIDE OF A TIMBER RAFTER – EXISTING BUILDING

All safety procedures must be complied with in accordance with the current safety code(s) of practice(s) for working at heights. Ensure safety at all times by being attached to anchor point approved safety equipment, using a scaffold or a secured ladder.

Positioning of RafterLink Anchor Point *(refer to appendix diagrams 2 and 3)*

The first RafterLink anchor point must be in a position easily reached by a secured ladder or a manhole access area.

Inspect the timber for strength

1. Inspect the timber for splits, cracks, knots, white ant damage and inspect the timber to make sure it is secured to the structure.
2. Minimum timber size is 35mm by 90mm (grade F5).
3. Attach anchors only to timber strong enough to support the anchor point.

⚠ If any doubt exists as to the strength of the structure an engineer should make the assessment.

Fixing RafterLink

1. Place the bracket in centre of the rafter, 80mm down from the under side of the roof sheeting.
2. 4.5mm pilot holes must be drilled into the timber, through the holes in the RafterLink, the full length of each screw to avoid timber from splitting.
3. 8 type 17 Hex Head 14g x 50mm screws in prepared holes.
4. (minimum timber size 90mm x 35mm F5).

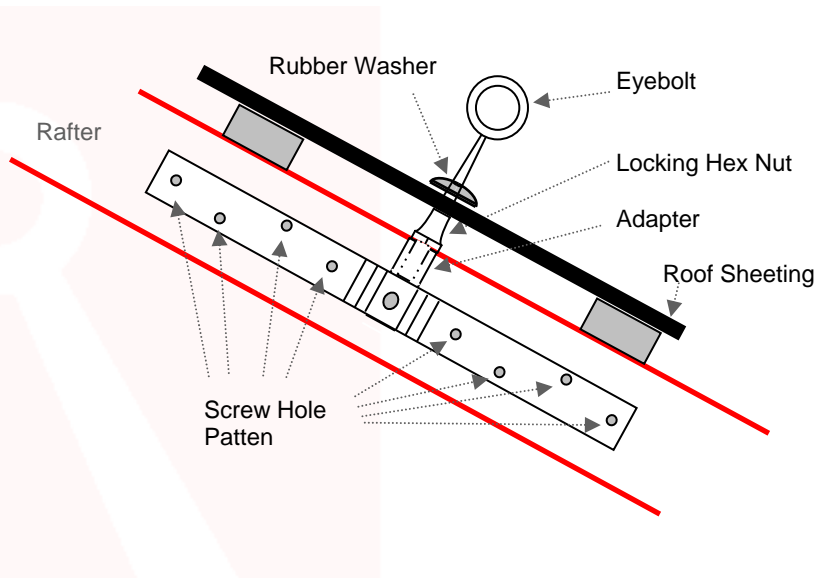

⚠ Lateral bracing straps must be used if there is a possibility of falling in a direction 45 to 90 degrees to the rafter *(refer to appendix diagram 4)*.

Installing the SafetyLink Stainless Steel Eyebolt

1. This requires one installer on the top of the roof sheeting and the other under the roof sheeting.
2. To stay safe while installing the first anchor point, the eyebolt should be positioned so you can reach it off a secured ladder or access point.
- ⚠** During installation you must be safe at all times.
3. The person on the roof makes sure the rubber washer is on the eyebolt before slipping the eyebolt through the 16mm hole.
4. The person underside of the roof screws the locking hex nut fully onto the eyebolt exposing 30mm of thread, coat threads with Loctite (IMPORTANT NOTE: Before applying Loctite 243 use Loctite 7471 primer to activate the surface according to manufacturer's instructions). *(refer to appendix diagram 1)*.
5. The person on the roof is now ready to screw the eyebolt all the way into the RafterLink.
6. Before tightening the locking hex nut turn the eyebolt to line up with the fall of the roof *(refer to appendix diagram 1)*.
7. The person underside of the roof tightens the locking hex nut using a spanner.

Threads need to have a minimum of **six full 360° turns** into the ultimate thread.

Note: use the same procedure to install a SafetyLink Abseiling Eyebolt, SafetyLink Intermediate T Bolt, SafetyLink End Anchor Taper Bolt.

Waterproofing (apply only to a dry surface)

The person on the roof uses a sealant between the rubber hat washer and the roof sheeting to waterproof the roof.

The SafetyLink anchor point is now ready for use, giving you an anchor point to attach to while installing the next SafetyLink.



INSTALLATION: TO A TIMBER TRUSS AT THE TOP OF THE RIDGE

All safety procedures must be complied with in accordance with the current safety code(s) of practice(s) for working at heights. Ensure safety at all times by being attached to anchor point approved safety equipment, using a scaffold or a secured ladder.

Positioning of HingeLink Anchor Point (refer to appendix diagrams 2 and 3)

The first HingeLink anchor point must be in a position easily reached by a secured ladder or a manhole access area.

Inspect the timber for strength

1. Inspect for splits, cracks, knots, white ant damage and to see how well the timber is secured to the structure.
2. Minimum timber size is 35mm by 90mm (grade F5).
3. Attach anchors only to timber able to support the anchor point.

⚠ If any doubt exists as to the strength of the structure an engineer should make the assessment.

Fixing HingeLink Stainless Steel Bracket

1. Placing the eyebolt in the HingeLink makes it easier to check the eyebolt for plumb.
2. Place the HingeLink over the truss and down either side sandwiching the truss making sure the eyebolt is plumb then mark and drill three at 12.2mm holes.
3. Use three only 12mm mild steel bolts (coat threads with Loctite).

Fixing the SafetyLink Stainless Steel Eyebolt

1. When screwing the locking hex nut onto the eyebolt make sure it is fully screwed up exposing 30 mm of thread, coat threads with Loctite (IMPORTANT NOTE: Before applying Loctite 243 use Loctite 7471 primer to activate the surface according to manufacturer's instructions). (refer to appendix diagram 1).
2. Place the hoop iron strap along the rafter and screw the eyebolt through the strap and into the HingeLink, tighten the locking hex nut using a spanner.
3. Then screw the strap down onto the rafters of the truss using 6 of 12g x 40mm screws.

Note: use the same procedure to install a SafetyLink Abseiling Eyebolt, SafetyLink Intermediate T Bolt, SafetyLink End Anchor Taper Bolt. This gives you an anchor point to attach to while installing the next SafetyLink.

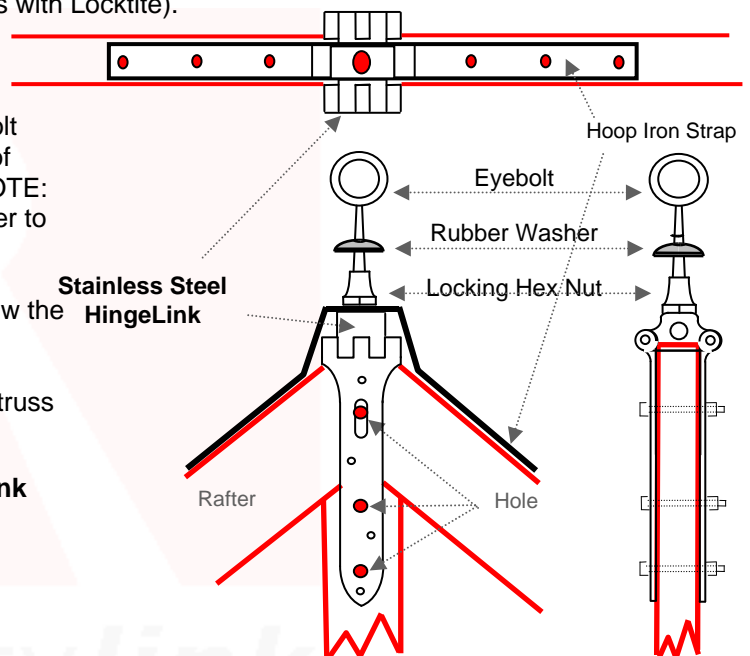

Relocating the eyebolts during the installation of a roof

You must be safely attached to an anchor point or using an alternative form of roof safety while removing and replacing the eyebolts. Use a spanner to release the locking hex nut then unscrew the eyebolt and remove the locking hex nut.

Marking the hole in the roof surface

1. Measure the position using two reference points and drill a 16mm hole.
2. For a metal roof simply screw a marker pin into the HingeLink and lay the sheet or ridge in position and push down on the roof sheet. The pin should mark the position of the 16mm hole to be drilled.

Ready to replace the eyebolt

1. The rubber washer should be on the eyebolt, place the eyebolt through the 16mm hole and screw the locking hex nut onto the eyebolt exposing 30mm of thread (coat threads with Loctite) (refer to appendix diagram 1).
2. Screw the eyebolt all the way into the HingeLink.
3. Before tightening the locking hex nut turn the eyebolt to line up with the fall of the roof (refer to appendix diagram 1).
4. Tighten the locking hex nut using a spanner.

Threads need to have a minimum of six full 360° turns into the ultimate thread.

Waterproofing (apply only to a dry surface)

Use a sealant between the rubber washer and the roof sheeting to waterproof the roof.

The SafetyLink anchor point is now ready for use, giving you an anchor point to attach to while installing the next SafetyLink.



INSTALLATION: TO A STEEL C OR Z PURLIN

All safety procedures must be complied with in accordance with the current safety code(s) of practice(s) for working at heights. Ensure safety at all times by being attached to anchor point approved safety equipment, using a scaffold or a secured ladder.

Positioning of PurLink (refer to appendix diagrams 2 and 3)

The first PurLink anchor point must be in a position easily reached by a secured ladder or a manhole access area.

Inspect the steel for strength

Inspect how well the steel purlin is secured to the structure. Minimum steel purlin gauge 1.2mm.

⚠ If any doubt exists as to the strength of the structure an engineer should make the assessment.

Marking and Drilling the PurLink to Steel C and Z Purlin

1. This requires one installer on the top of the roof sheeting and the other under the roof sheeting.
2. When working from under the roof sheeting first establish the centre of the high part of the profile of the roof sheeting and mark the centre of the purlin.
3. Once the position of the PurLink is established simply drill a 6mm pilot hole through the purlin and roof sheeting.
4. From above the roof sheeting, drill a 25mm hole through the roof sheeting only, then drill a 16mm hole through the purlin. **You are now ready to install the eyebolt.**

Fixing the SafetyLink Stainless Steel Eyebolt

1. Place the rubber washer onto the eyebolt.
2. When screwing the locking hex nut onto the stainless steel eyebolt make sure it is fully screwed up exposing 30 mm of thread, coat threads with Loctite (IMPORTANT NOTE: Before applying Loctite 243 use Loctite 7471 primer to activate the surface according to manufacturer's instructions). (refer to appendix diagram 1).
3. Place the eyebolt through the 16mm hole, make sure the eyebolt is lined up with the fall of the roof (refer to appendix diagram 1).
4. Now the person under the roof sheeting fits the steel block then a washer onto the eyebolt before screwing on a 16mm stainless steel nut.
5. Tighten using a spanner.

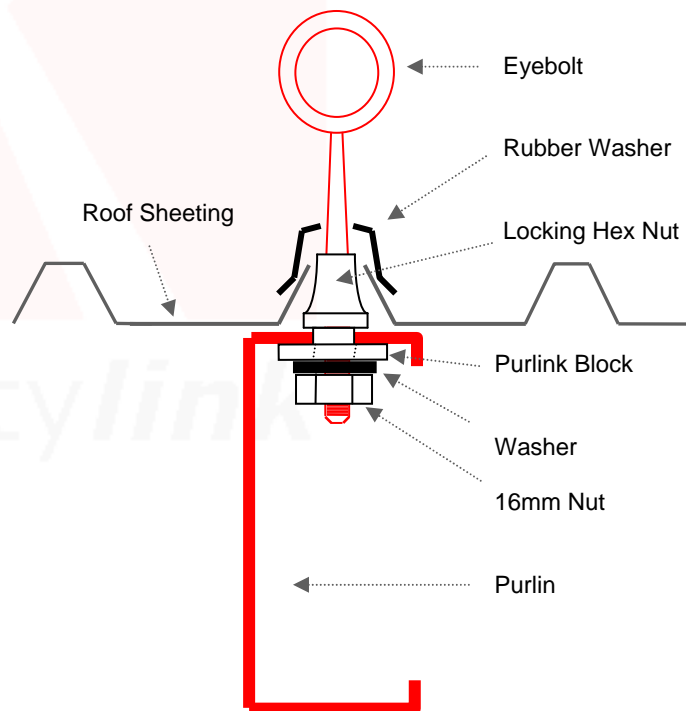

Threads need to have a minimum of **six full 360° turns** into the ultimate thread.

Note: use the same procedure to install a SafetyLink Abseiling Eyebolt, SafetyLink Intermediate T Bolt, SafetyLink End Anchor Taper Bolt.

Waterproofing (apply only to a dry surface)

Use a sealant between the rubber washer and the roof sheeting to waterproof the roof.

The PurLink anchor point is now ready for use, giving you an anchor point to attach to while installing the next SafetyLink.



RETROLINK ANCHOR POINT (BLOCK)

Product Code: RETRO001

INSTALLATION: TO A STEEL C OR Z PURLIN

All safety procedures must be complied with in accordance with the current safety code(s) of practice(s) for working at heights. Ensure safety at all times by being attached to anchor point approved safety equipment, using a scaffold or a secured ladder.

Positioning of RetroLink (refer to appendix diagrams 2 and 3)

The first RetroLink anchor point must be in a position easily reached by a secured ladder or a manhole access area.

Inspect the steel for strength

Inspect how well the steel purlin is secured to the structure. Minimum steel purlin gauge 1.2mm.

⚠ If any doubt exists as to the strength of the structure an engineer should make the assessment.

Locating the Purlin

If the roof is screwed through the roof sheets simply follow the screws. If the roof sheeting has concealed fixings, finding the purlin is more difficult. You can lift a sheet to find the purlin or by walking on the roof you can feel the purlin. You can also use a strong magnet to find the purlin. **⚠ During installation you must be safe at all times.**

After locating Purlin

1. You must establish the open side of the c-section purlin.
2. Drill a 10mm hole on one side of the purlin then use the installation tool to check for the open side (the retro rubber washer will cover the hole).
3. Place retro rubber washer and locking hex nut on the eyebolt screw the locknut up exposing 30mm of thread, coat threads with Loctite (IMPORTANT NOTE: Before applying Loctite 243 use Loctite 7471 primer to activate the surface according to manufacturer's instructions). (refer to appendix diagram 1).

After establishing the open side of the purlin

1. Place the template on the roof to line up the template with the purlin, then using a pencil mark around the template and mark the hole on roof sheet and drill a 16mm hole.
2. Using tin snips cut the roof sheeting around the template, you are now ready to fit the RetroLink anchor point.

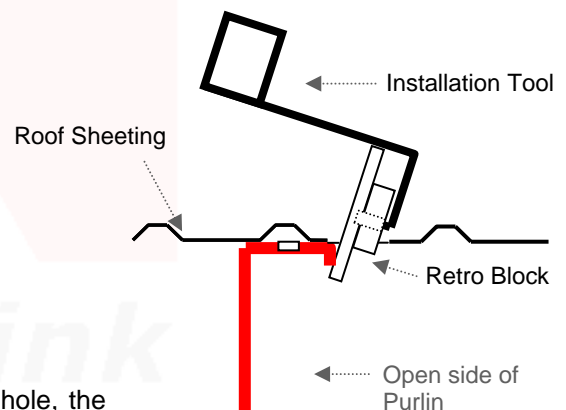
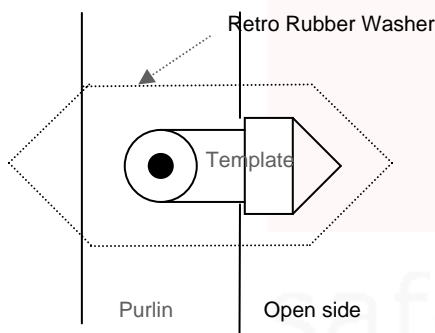

3. Use the installation tool to lower the retro block through the hole, the block then automatically drops into the right position.
4. Lift the retro block up to line up with the hole and screw in the eyebolt all the way (30mm of thread), coat threads with Loctite (IMPORTANT NOTE: Before applying Loctite 243 use Loctite 7471 primer to activate the surface according to manufacturer's instructions).
5. Before tightening the locking hex nut turn the eyebolt to line up with the fall of the roof.
6. Tighten locking hex nut using a spanner (refer to appendix diagram 1).

Note: use the same procedure to install a SafetyLink Abseiling Eyebolt, SafetyLink Intermediate T Bolt, SafetyLink End Anchor Taper Bolt.

Waterproofing (apply only to a dry surface)

Use a sealant between the retro rubber washer and the roof sheeting, make sure you use plenty of sealant where it is needed as it is costly to return and do it again.

Secure the retro rubber washer to the roof lining using a minimum of eight fixing screws or pop rivets approximately 50mm apart.

The SafetyLink anchor point is now ready for use, giving you an anchor point to attach to while installing the next SafetyLink.

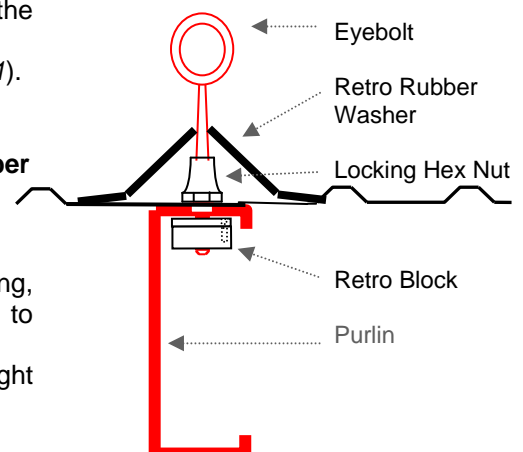



RETROLINK ANCHOR POINT (TUBE)

Product Code: RETRO003

INSTALLATION: TO A STEEL C OR Z PURLIN

All safety procedures must be complied with in accordance with the current safety code(s) of practice(s) for working at heights. Ensure safety at all times by being attached to anchor point approved safety equipment, using a scaffold or a secured work platform.

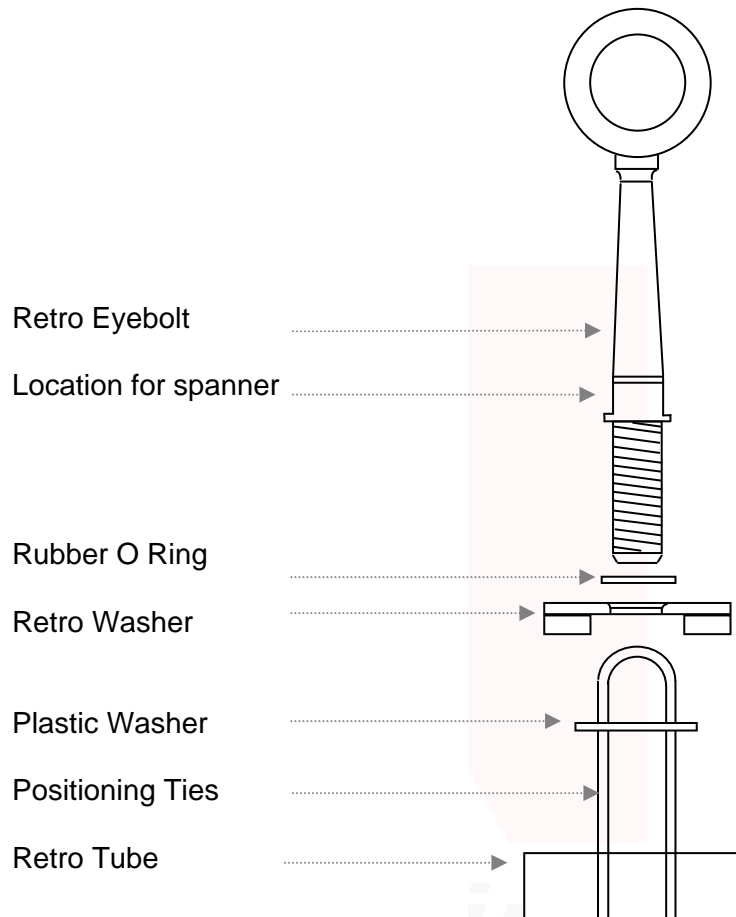

Positioning of RetroLink

The first RetroLink anchor point must be in a position easily reached by a secured ladder or a manhole access area.

Inspect the steel for strength

Inspect how well the steel purlin is secured to the structure. Minimum steel purlin gauge 1.2mm.

⚠ If any doubt exists as to the strength of the structure an engineer should make the assessment.

Locating the Purlin

If the roof is screwed through the roof sheets simply follow the screws. If the roof sheeting has concealed fixings, finding the purlin is more difficult. You can lift a sheet to find the purlin or by walking on the roof you can feel the purlin. You can also use a strong magnet to find the purlin.

⚠ During installation you must be safe at all times.



INSTALLATION: TO A STEEL C OR Z PURLIN

Installation of the Retro Tube

1. Locate the centre of the purlin and drill a 25mm hole.
2. Hold onto the positioning ties and slide the Retro Tube vertically through the 25mm hole. Once the tube is through the hole, reorientate it to a horizontal position.
3. Slide the plastic washer down the positioning ties and draw the Retro Tube up to the underside of the purlin or post.

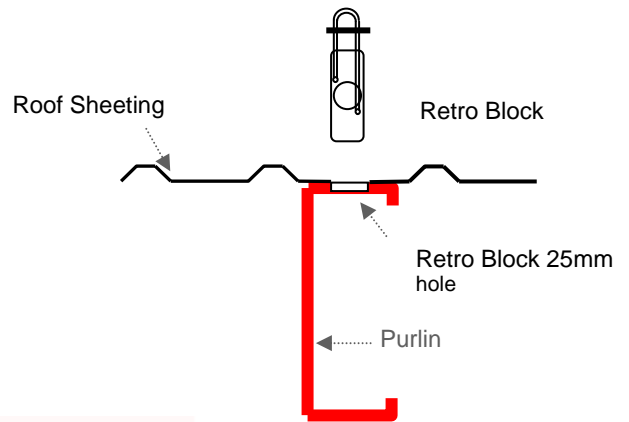

Installation of Retro Eyebolt

4. Place the Retro Eyebolt through the Retro Washer. Apply silicon to the roof sheeting around the plastic washer.
5. Coat Eyebolt thread with Loctite (IMPORTANT NOTE: Before applying Loctite 243 use Loctite 7471 primer to activate the surface according to manufacturer's instructions).
6. Thread the Retro Eyebolt into the Retro Tube then tighten the eyebolt so it lines up with the run of the roof.

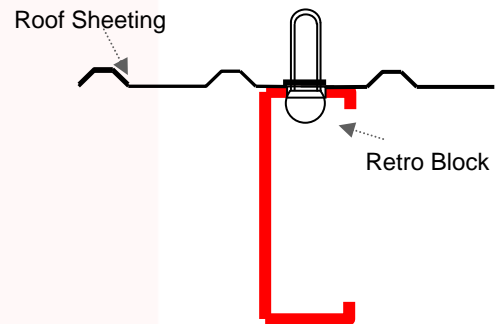

Threads need to have a minimum of **six full 360° turns** into the ultimate thread.

Note: use the same procedure to install a SafetyLink Intermediate T Bolt, SafetyLink End Anchor Taper Bolt.

Waterproofing (apply only to a dry surface)

Use a sealant between the retro washer and the roof sheeting, make sure you use plenty of sealant where it is needed as it is costly to return and do it again.

The SafetyLink anchor point is now ready for use, giving you an anchor point to attach to while installing the next SafetyLink.

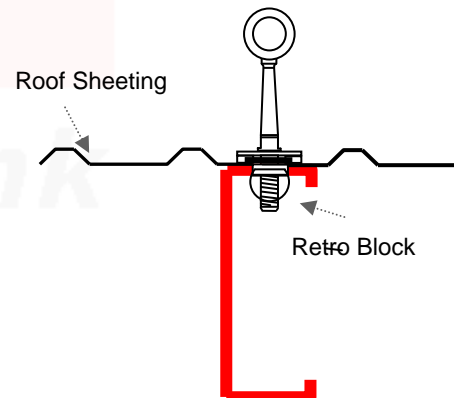

INSTALLATION: TO THE SURFACE OF A ROOF

- ⚠ **FROGLINK ANCHORS MUST NOT BE USED FOR ROPE ACCESS (ABSEILING).**
- ⚠ **MAXIMUM USER PER FROGLINK IS TWO (2).**

All safety procedures must be complied with in accordance with the current safety code(s) of practice(s) for working at heights. Ensure safety at all times by being attached to anchor point approved safety equipment, using a scaffold or a secured ladder.

Positioning of FrogLink Anchor Point (refer to appendix diagrams 2 and 3)

The first FrogLink must be in a position easily reached by a secured ladder or a manhole access point. Access to underside of roof is not required. It is recommended the FrogLink be installed to the top of the roof sheeting profile, where this is not practical the Froglink may be installed into the pan away from debris.

Inspect the structure and roof sheeting

1. Inspect for splits, rust, corrosion damage and to see how well the roof sheet is secured to the structure.
2. Minimum roof sheet size is 0.42mm, aluminium sheeting 0.7mm.
3. Attach anchors only to roof sheets able to support the anchor point.

Live Load on Anchors: 25 degrees is reaching the limit for our surface mounted anchors. Note: the real issue is putting a live load on these anchors, they are not abseil anchors and therefore if they are subjected to a live load this may trigger the energy absorbing regions. All our surface mounted anchors have been tested in a free fall situation so should a person fall at above 25 degrees pitch roof the anchor will easily arrest a fall.

- ⚠ If any doubt exists as to the strength of the structure or roof sheets an engineer should make the assessment.
- ⚠ During installation you must be safe at all times.
- ⚠ Installation must be carried out by, or under the supervision of a competent person.

COMPONENTS:

- 1 x FrogLink Plate
- 7 x Gesipa Bulbtite Rivets, RV6605-9-6W (Drill Size 7.8-8.2mm, 27.7mm length, 1.0-9.5mm grip range, Aluminium)

FrogLink Plate

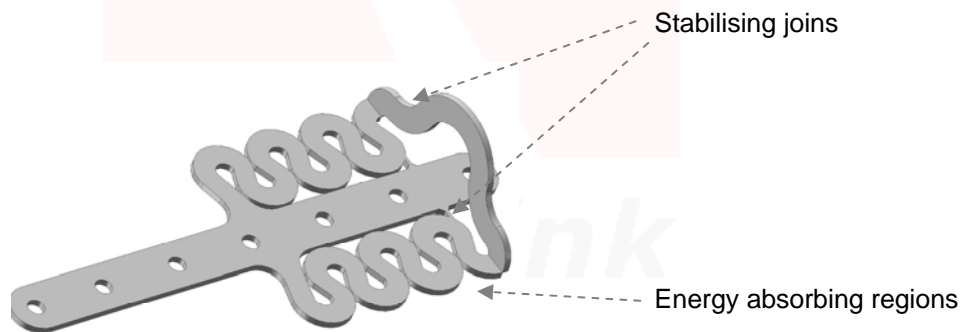

Rivets

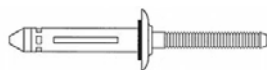

Multidirectional

WARNING: FrogLink Anchors should be positioned a minimum of 2 metres from the edge on Cliplock roofs.

1. Place the FrogLink on the surface of the roof sheets in the required location.
2. Drill Seven (7) 8mm holes into the roof sheets through the locating holes on the FrogLink.
3. Secure the FrogLink to the roof by riveting through the holes in the FrogLink Anchor and the roof sheet using 8mm Gesipa rivets.

The SafetyLink Anchor Point is now ready for use, giving you an anchor point to attach to while installing the next SafetyLink.



INSTALLATION: TO THE SURFACE OF A ROOF – Single Plate

⚠ SURFACE MOUNTED ANCHORS MUST NOT BE USED FOR ROPE ACCESS (ABSEILING).

All safety procedures must be complied with in accordance with the current safety code(s) of practice(s) for working at heights. Ensure safety at all times by being attached to anchor point approved safety equipment, using a scaffold or a secured ladder.

Positioning of SurfaceLink Anchor Point (refer to appendix diagrams 2 and 3)

The first SurfaceLink must be in a position easily reached by a secured ladder or a manhole access point. Access to underside of roof is not required.

Inspect the structure and roof sheeting

1. Inspect for splits, rust, corrosion damage and to see how well the roof sheet is secured to the structure.
2. Minimum roof sheet size is 0.42mm, aluminium sheeting 0.7mm.
3. Attach anchors only to roof sheets able to support the anchor point.

Live Load on Anchors: 25 degrees is reaching the limit for our surface mounted anchors. Note: the real issue is putting a live load on these anchors, they are not abseil anchors and therefore if they are subjected to a live load this may trigger the energy absorbing regions. All our surface mounted anchors have been tested in a free fall situation so should a person fall at above 25 degrees pitch roof the anchor will easily arrest a fall.

⚠ If any doubt exists as to the strength of the structure or roof sheets an engineer should make the assessment.

⚠ During installation you must be safe at all times.

COMPONENTS:

- 1 x Stainless Steel Eyebolt
- 1 x Locking Hex Nut
- 1 x Advance SurfaceLink Plate
- 1 x 50mm Rubber Washer
- 1 x 50mm Washer
- 1 x Stainless Steel 16mm Nut

Eyebolt



Locking Hex Nut



Advance Surface Plate

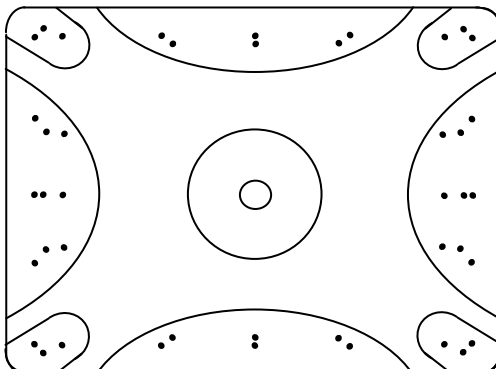

50mm Rubber Washer

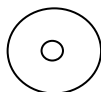

50mm Washer

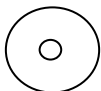

16mm Nut



SETTING OUT:

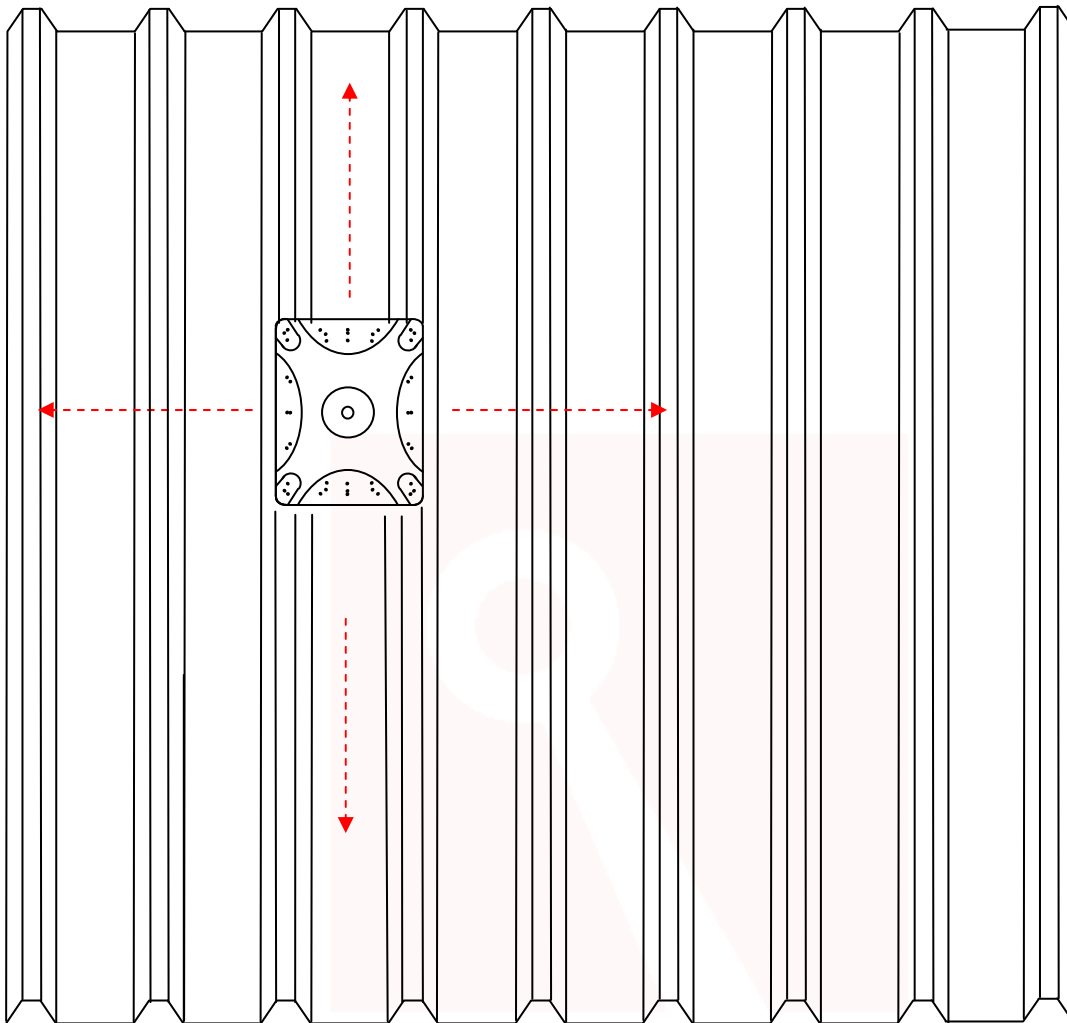

Multidirectional

Inspect the steel for strength

Inspect how well the metal roof sheeting is secured to the structure. Minimum sheet gauge 0.42mm.

⚠ If any doubt exists as to the strength of the structure an engineer should make the assessment.

WARNING:

Surface Mounted Anchors should be positioned a minimum of 2 metres from the edge on Cliplock roofs.

Place Surface Mounted Anchor in desired location to match holes with roof profile.



ADVANCE SURFACELINK ANCHOR

Product Code: ASURF001

INSTALLATION: TO THE SURFACE OF A ROOF – Single Plate

ASSEMBLING: STEPS: 1 - 5

STEP 1

Apply adhesive waterproofing membrane under rivet location.

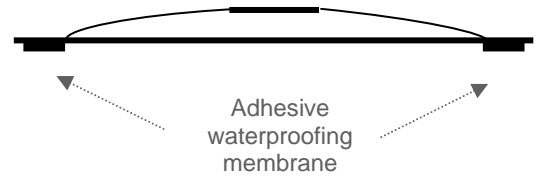
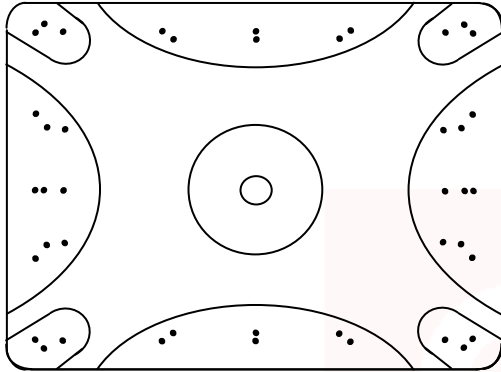

STEP 2

Screw locking hex nut into eyebolt leaving 30mm of thread, coat threads with Loctite (IMPORTANT NOTE: Before applying Loctite 243 use Loctite 7471 primer to activate the surface according to manufacturer's instructions).

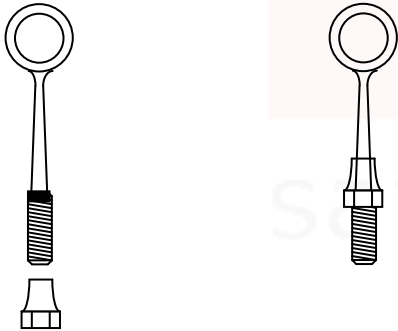

STEP 3

Insert eyebolt through Advance SurfaceLink Plate.

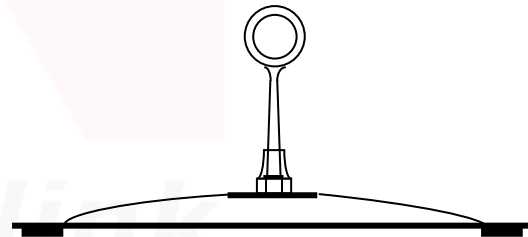

STEP 4

Apply a 50mm rubber washer, 50mm washer and nut to underside of the surface plate, tighten nut finger tight (coat threads with Loctite).

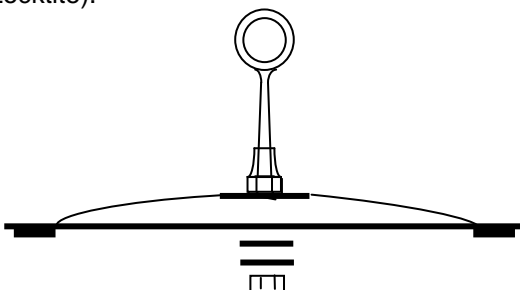

STEP 5

Tighten nut and Locking Hex Nut making certain eyebolt lines up with fall of roof.

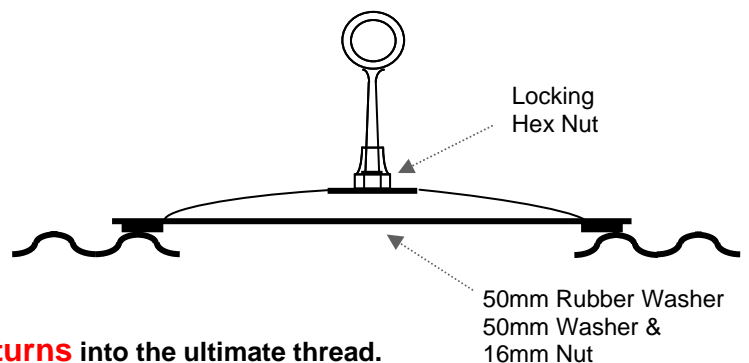

Threads need to have a minimum of **six full 360° turns** into the ultimate thread.

INSTALLING: STEPS: 1 to 3

WARNING:

Surface Mounted Anchors should be positioned a minimum of 2 metres from the edge on Cliplock roofs.

1. Place SurfaceLink on surface of roof sheets in required location.
2. Drill Ten (10) 8mm holes into roof sheets through locating holes on both sides of the SurfaceLink (5 each side).
3. Secure the SurfaceLink to the roof by riveting through holes in surface mounted anchor and roof sheet using Gesipa Bulbrite Rivets, RV6605-9-6W (Drill Size 7.8-8.2mm, 27.7mm length, 1.0-9.5mm grip range, Aluminium).

⚠ During installation you must be safe at all times.

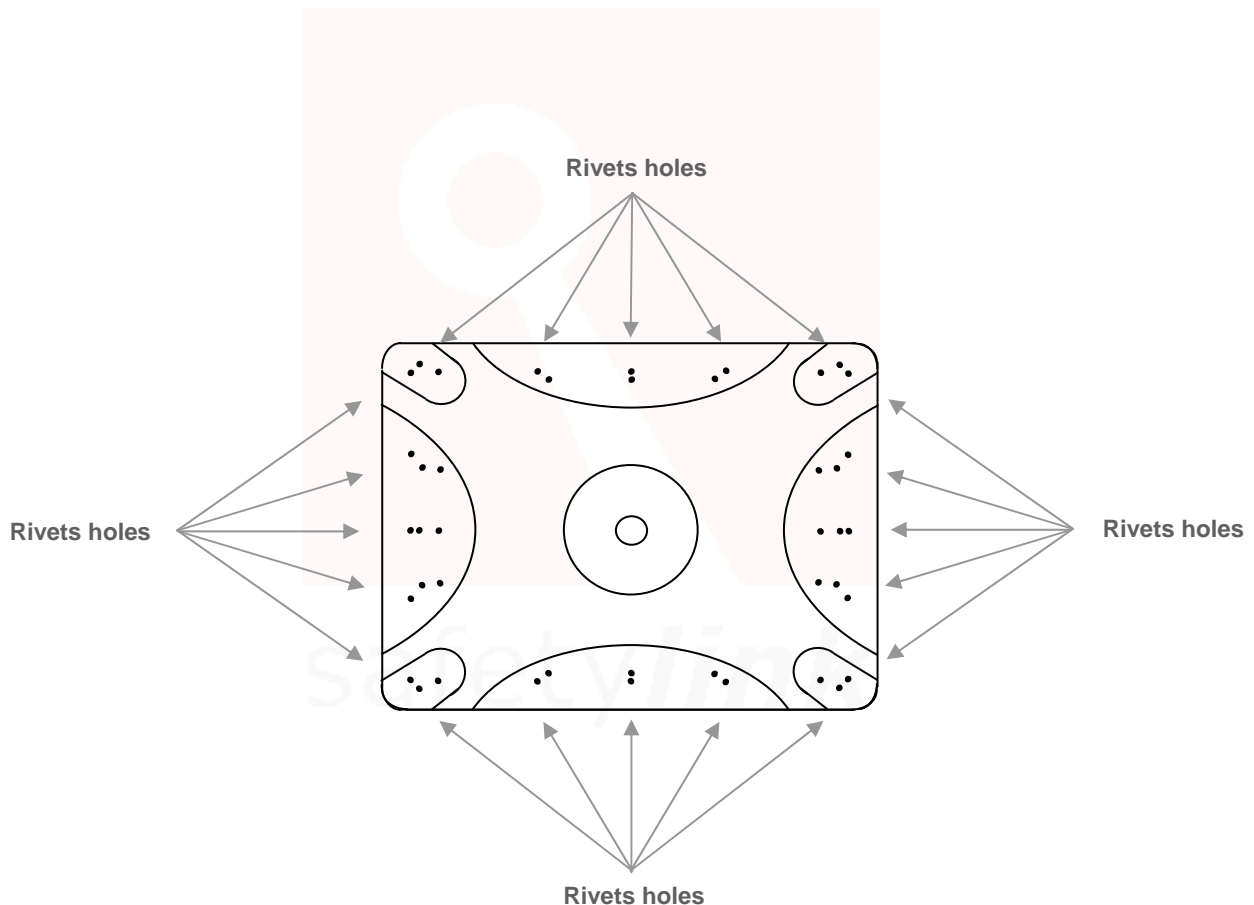

The SafetyLink Anchor Point is now ready for use, giving you an anchor point to attach to while installing the next SafetyLink.

Live Load on Anchors: 25 degrees is reaching the limit for our surface mounted anchors. Note: the real issue is putting a live load on these anchors, they are not abseil anchors and therefore if they are subjected to a live load this may trigger the energy absorbing regions. All our surface mounted anchors have been tested in a free fall situation so should a person fall at above 25 degrees pitch roof the anchor will easily arrest a fall.



STAINLESS STEEL SURFACELINK ANCHOR

Product Code: SURFL001

INSTALLATION: TO THE SURFACE OF A ROOF – Double Plates

⚠ SURFACE MOUNTED ANCHORS MUST NOT BE USED FOR ROPE ACCESS (ABSEILING).

All safety procedures must be complied with in accordance with the current safety code(s) of practice(s) for working at heights. Ensure safety at all times by being attached to anchor point approved safety equipment, using a scaffold or a secured ladder.

Positioning of SurfaceLink Anchor Point (refer to appendix diagrams 2 and 3)

The first SurfaceLink must be in a position easily reached by a secured ladder or a manhole access point. Access to underside of roof is not required.

Inspect the structure and roof sheeting

1. Inspect for splits, rust, corrosion damage and to see how well the roof sheet is secured to the structure.
2. Minimum roof sheet size is 0.42mm, aluminium sheeting 0.7mm.
3. Attach anchors only to roof sheets able to support the anchor point.

Live Load on Anchors: 25 degrees is reaching the limit for our surface mounted anchors. Note: the real issue is putting a live load on these anchors, they are not abseil anchors and therefore if they are subjected to a live load this may trigger the energy absorbing regions. All our surface mounted anchors have been tested in a free fall situation so should a person fall at above 25 degrees pitch roof the anchor will easily arrest a fall.

- ⚠ If any doubt exists as to the strength of the structure or roof sheets an engineer should make the assessment
- ⚠ During installation you must be safe at all times.

COMPONENTS:

- 1 x Stainless Steel Eyebolt
- 1 x Locking Hex Nut
- 1 x 70mm Washer
- 1 x 50mm Washer
- 2 x Side Plates
- 1 x Stainless Steel 16mm Nut

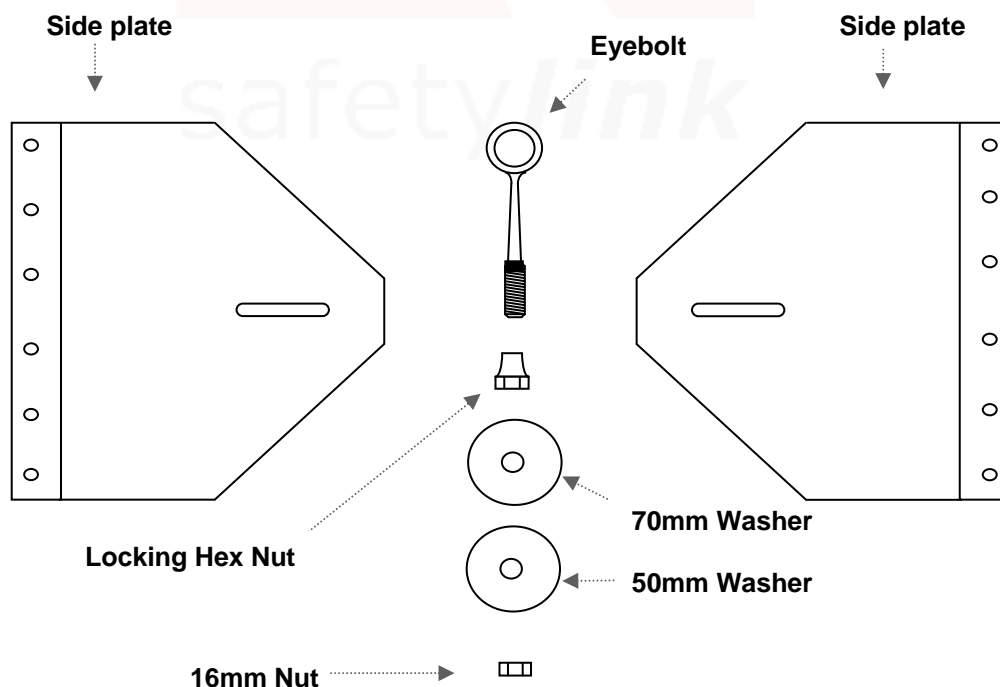



STAINLESS STEEL SURFACELINK ANCHOR

INSTALLATION: TO THE SURFACE OF A ROOF – Double Plates

ASSEMBLING: STEPS: 1 - 5 of 8

STEP 1

Overlap side plates, aligning slots for Eyebolt.

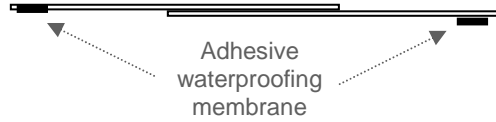
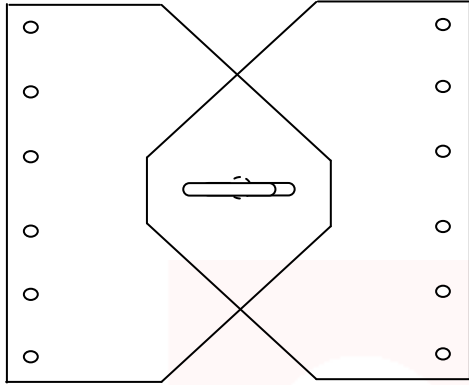

STEP 2

Screw locking hex nut into eyebolt leaving 30mm of thread, coat threads with Loctite (IMPORTANT NOTE: Before applying Loctite 243 use Loctite 7471 primer to activate the surface according to manufacturer's instructions).

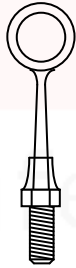

STEP 3

Add 70mm washer to eyebolt thread.

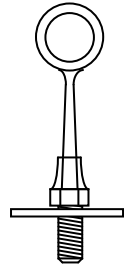

STEP 4

Insert eyebolt through side plates.

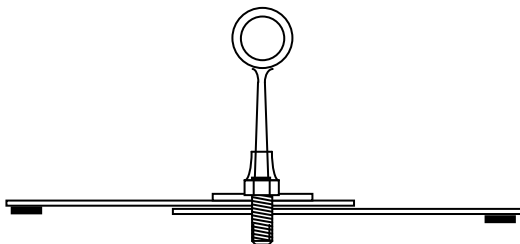

STEP 5

Apply 50mm washer and nut, tighten nut finger tight (coat threads with Locktite).

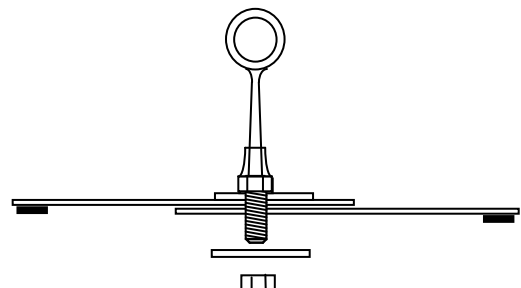



STAINLESS STEEL SURFACELINK ANCHOR

INSTALLATION: TO THE SURFACE OF A ROOF – Double Plates

ASSEMBLING: STEPS: 6 - 7 of 7

STEP 6

Adjust side plates and Eyebolt in slot to correct profile of roof.

STEP 7

Tighten nut and Locking Hex Nut making certain eyebolt lines up with fall of roof.

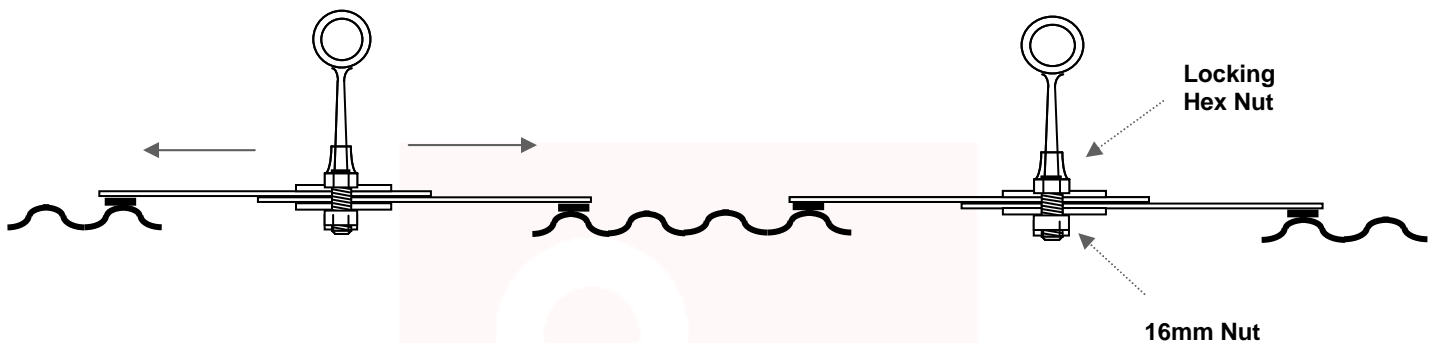

Threads need to have a minimum of **six full 360° turns** into the ultimate thread.

INSTALLING: STEPS: 1 to 3

WARNING: Surface Mounted Anchors should be positioned 2 metres from the edge on Cliplock roofs.

STEP 1

Place SurfaceLink anchor on surface of roof sheets in required location.

STEP 2

Drill 12 x 8mm holes into roof sheets through rivet holes on both sides of the SurfaceLink anchor.

STEP 3

Secure the SurfaceLink anchor to the roof by riveting through anchor and roof sheet using 8mm Gesipa rivets.

⚠ During installation you must be safe at all times.

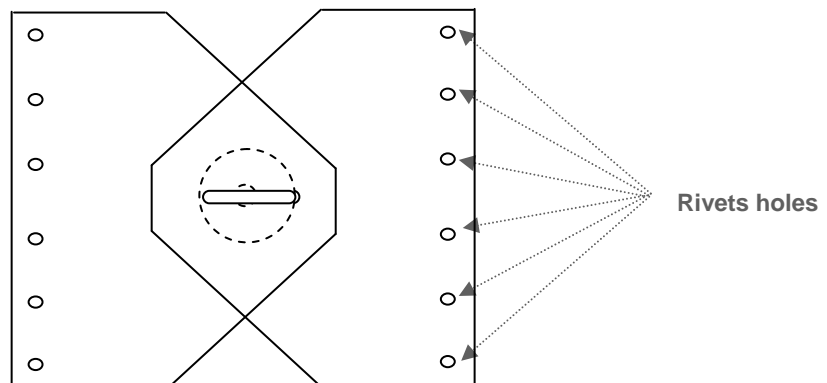

The SafetyLink Anchor Point is now ready for use, giving you an anchor point to attach to while installing the next SafetyLink.



INSTALLATION: INTO CONCRETE

(Comes as a single ready to install unit)

All safety procedures must be complied with in accordance with the current safety code(s) of practice(s) for working at heights. Ensure safety at all times by being attached to anchor point approved safety equipment, using a scaffold or a secured ladder.

Positioning of WindowLink Anchor Point (The pendulum effect still applies)

(refer to appendix diagram 2 and 3)

The first Anchor Point must be in a position easily reached by a secured ladder or a manhole access point.

⚠ During installation you must be safe at all times.

Locating the steel in the concrete

To comply with Australian Standards.

Digital metal detector: BOSCH DMO 10. Use the detector to locate the steel in the concrete when positioning the WindowLink. This ensures steel is avoided when drilling.

WindowLink should not be positioned close to an edge

If any doubt exists as to the strength of the structure an engineer should make the assessment.

Drilling the hole

1. Two holes must be drilled.
2. Drill first hole using a 55mm hole saw drill to a depth of 20mm.
3. Then drill second hole with a 28mm width and a depth of 122mm.

Preparing the hole

1. Using a small chisel remove the excess concrete to fit the shape of the WindowLink.
2. The hole must be moisture and dust free, remove the dust using compressed air.

Installing chemical anchor

Recommended chemical anchor is Power-Fast epoxy injection adhesive gel.

1. Read instructions on product carefully.
2. The whole surface of the WindowLink unit in contact with the concrete must use sufficient adhesive gel as specified on the product.

Testing for Free fall-arrest for one person: 15 kN ultimate strength

1. To comply with Australian Standards each WindowLink unit must be tested after installation.
2. Allow sufficient time at least 48 hours for curing before testing.
3. Test consists of ultimate pull out force proof loading to 50% of design purpose of anchorage.

Note: Drilled-in anchorages such as friction and glued-in anchorages shall be placed so that the shear load is at least twice the tension load. For collared eyebolts this translates to a pull at an angle not exceeding 20 degrees to the surface in which the bolt is installed.

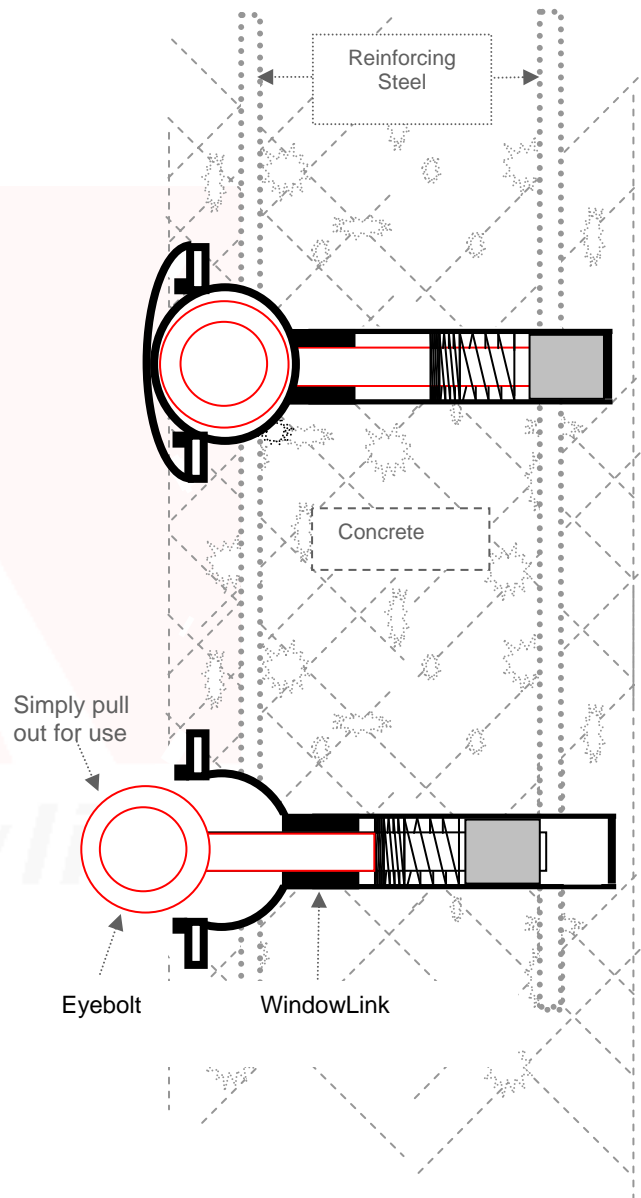

INSTALLATION: INTO CONCRETE

(Comes as a single ready to install unit)

All safety procedures must be complied with in accordance with the current safety code(s) of practice(s) for working at heights. Ensure safety at all times by being attached to anchor point approved safety equipment, using a scaffold or a secured ladder.

Positioning of SwiveLink Anchor Point (refer to appendix diagram 2 and 3)

(The pendulum effect still applies) The first SwiveLink Anchor Point must be in a position easily reached by a secured ladder or a manhole access point.

⚠ During installation you must be safe at all times.

Locating the steel in the concrete

To comply with Australian Standards.
Digital metal detector: BOSCH DMO 10. Use the detector to locate the steel in the concrete when positioning the SwiveLink. This ensures steel is avoided when drilling.

Positioning the SwiveLink close to an edge

If any doubt exists as to the strength of the structure an engineer should make the assessment.

Drilling the hole

Drill a 28mm hole to a depth of 100mm.

Preparing the hole

1. The hole must be moisture and dust free.
2. Remove the dust using compressed air.

Installing chemical anchor

Recommended chemical anchor is Power-Fast epoxy injection adhesive gel.

1. Read instructions on product carefully.
2. The whole surface of the SwiveLink unit in contact with the concrete must use sufficient adhesive gel as specified on the product.

Testing for Free fall-arrest for one person: 15 kN ultimate strength

1. To comply with Australian Standards each SwiveLink unit must be tested after installation.
2. Allow sufficient time at least 48 hours for curing before testing.
3. Test consists of ultimate pull out force proof loading to 50% of design purpose of anchorage.

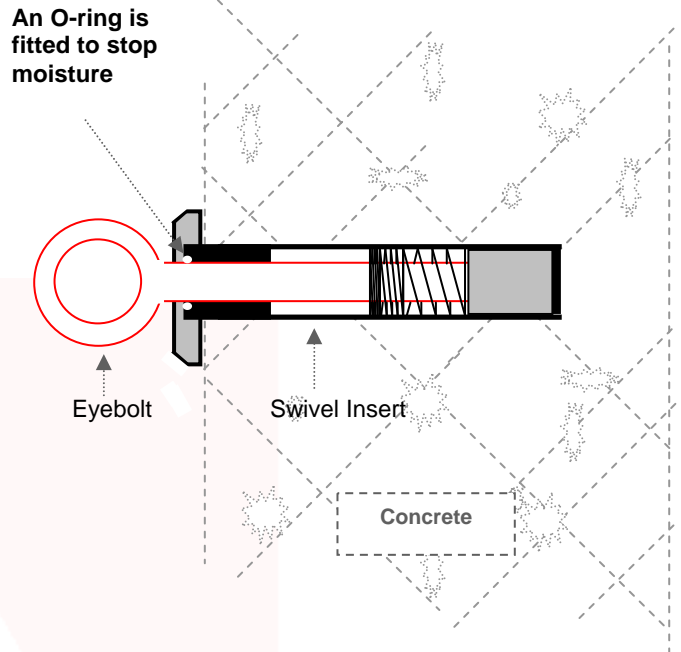

Steel Mounted SwiveLink

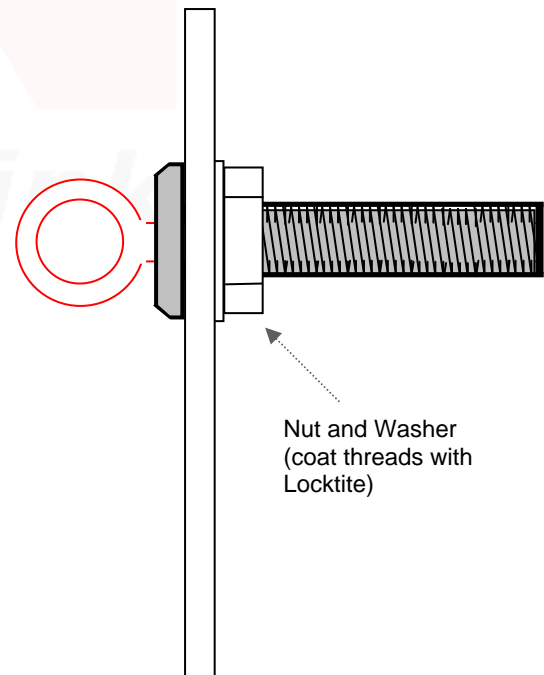

Note: Drilled-in anchorages such as friction and glued-in anchorages shall be placed so that the shear load is at least twice the tension load. For collared eyebolts this translates to a pull at an angle not exceeding 20 degrees to the surface in which the bolt is installed.



INSTALLATION: INTO CONCRETE

All safety procedures must be complied with in accordance with the current safety code(s) of practice(s) for working at heights. Ensure safety at all times by being attached to anchor point approved safety equipment, using a scaffold or a secured ladder.

Positioning of ConcreteLink Anchor Point (The pendulum effect still applies)

(refer to appendix diagram 2 and 3) The first ConcreteLink Anchor Point must be in a position easily reached by a secured ladder or a manhole access point.

⚠ During installation you must be safe at all times.

Locating the steel in the concrete

To comply with Australian Standards.

Digital metal detector: BOSCH DMO 10.

Use the detector to locate the steel in the concrete when positioning the ConcreteLink. This ensures steel is avoided when drilling.

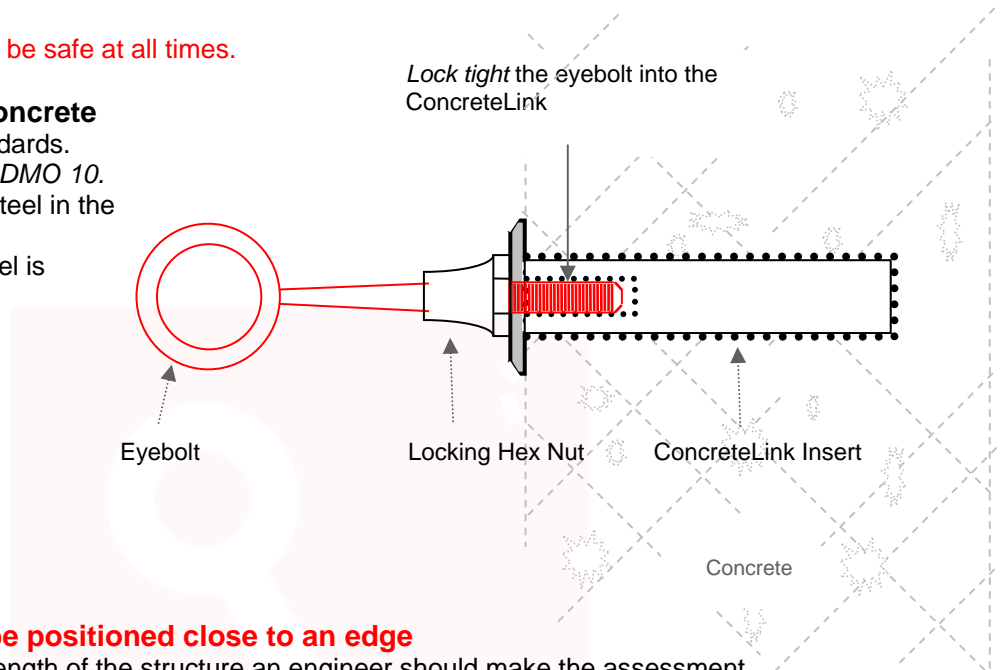

ConcreteLink should not be positioned close to an edge

If any doubt exists as to the strength of the structure an engineer should make the assessment.

Drilling the hole

Drill a 28mm hole to a depth of 100mm.

Preparing the hole

The hole must be moisture and dust free. Remove the dust using compressed air.

Installing the concrete insert

Recommended chemical anchor is Power-Fast epoxy injection adhesive gel.

1. Read instructions on product carefully.
2. The whole surface of the ConcreteLink unit in contact with the concrete must use sufficient adhesive gel as specified on the product.

Fitting the SafetyLink Stainless Steel Eyebolt

1. When screwing the locking hex nut onto the stainless steel eyebolt make sure it is fully screwed up exposing 30 mm of thread (coat threads with Loctite).
2. Then screw the eyebolt into the ConcreteLink.
3. Ensure the eyebolt is facing the right direction (refer to appendix diagram 1).
4. Use *lock tight* on the eyebolt thread to ensure that the unit cannot be tampered with, (IMPORTANT NOTE: Before applying Loctite 243 use Loctite 7471 primer to activate the surface according to manufacturer's instructions).

Note: use the same procedure to install a SafetyLink Abseiling Eyebolt, SafetyLink Intermediate T Bolt, SafetyLink End Anchor Taper Bolt.

Testing for Free fall-arrest for one person. 15 kN ultimate strength.

1. To comply with Australian Standards each ConcreteLink unit must be tested after installation.
2. Allow sufficient time at least 48 hours for curing before testing.
3. Test consists of ultimate pull out force proof loading to 50% of design purpose of anchorage.

Note: Drilled-in anchorages such as friction and glued-in anchorages shall be placed so that the shear load is at least twice the tension load. For collared eyebolts this translates to a pull at an angle not exceeding 20 degrees to the surface in which the bolt is installed.

INSTALLATION: INTO CONCRETE

All safety procedures must be complied with in accordance with the current safety code(s) of practice(s) for working at heights. Ensure safety at all times by being attached to anchor point approved safety equipment, using a scaffold or a secured ladder.

Positioning of ConcreteLink Collared Eyebolt Anchor Point (The pendulum effect still applies)
(refer to appendix diagram 2 and 3)

The first ConcreteLink Anchor Point must be in a position easily reached by a secured ladder or a manhole access point.

⚠ During installation you must be safe at all times.

Locating the steel in the concrete

To comply with Australian Standards.

Digital metal detector: BOSCH DMO 10.

Use the detector to locate the steel in the concrete when positioning the ConcreteLink. This ensures steel is avoided when drilling.

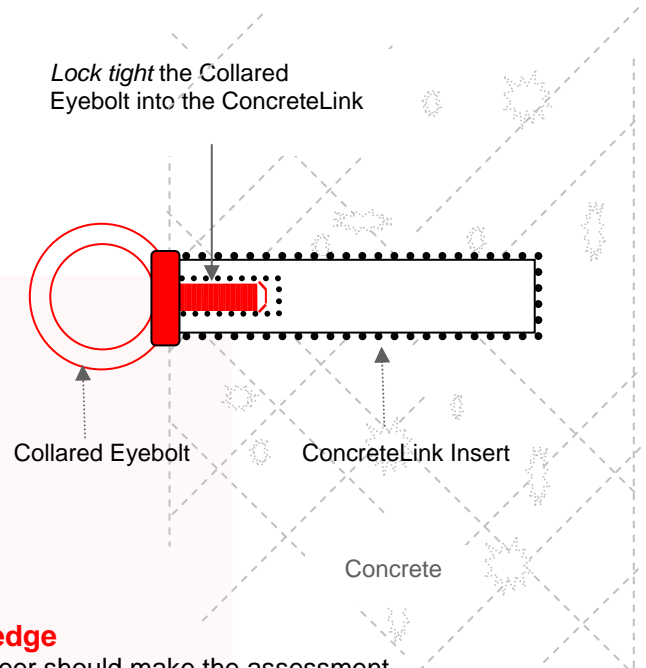

ConcreteLink should not be positioned close to an edge

If any doubt exists as to the strength of the structure an engineer should make the assessment.

Drilling the hole

Drill a 28mm hole to a depth of 100mm.

Preparing the hole

The hole must be moisture and dust free. Remove the dust using compressed air.

Installing the concrete insert

Recommended chemical anchor is Power-Fast epoxy injection adhesive gel.

3. Read instructions on product carefully.
4. Use sufficient adhesive gel as specified on the product instructions.

Fitting the SafetyLink Stainless Steel Collared Eyebolt

5. Screw the collared eyebolt into the ConcreteLink (coat threads with Loctite).
6. Ensure the collared eyebolt is facing the right direction (refer to appendix diagram 1).
7. Use *lock tight* on the collared eyebolt thread to ensure that the unit cannot be tampered with, (IMPORTANT NOTE: Before applying Loctite 243 use Loctite 7471 primer to activate the surface according to manufacturer's instructions).

Note: use the same procedure to install a SafetyLink Abseiling Eyebolt, SafetyLink Intermediate T Bolt, SafetyLink End Anchor Taper Bolt.

Testing for Free fall-arrest for one person. 15 kN ultimate strength.

To comply with Australian Standards each ConcreteLink unit must be tested after installation.

1. Allow sufficient time at least 48 hours for curing before testing.
2. Test consists of ultimate pull out force proof loading to 50% of design purpose of anchorage.

Note: Drilled-in anchorages such as friction and glued-in anchorages shall be placed so that the shear load is at least twice the tension load. For collared eyebolts this translates to a pull at an angle not exceeding 20 degrees to the surface in which the bolt is installed.



“EXTENDED” CONCRETELINK ANCHOR POINT

INSTALLATION: INTO CONCRETE

All safety procedures must be complied with in accordance with the current safety code(s) of practice(s) for working at heights. Ensure safety at all times by being attached to anchor point approved safety equipment, using a scaffold or a secured ladder.

Positioning of ConcreteLink Anchor Point (The pendulum effect still applies)

(refer to appendix diagram 2 and 3)

The first ConcreteLink Anchor Point must be in a position easily reached by a secured ladder or a manhole access point. ⚠ During installation you must be safe at all times.

ConcreteLink SHOULD NOT be positioned close to an edge

If any doubt exists as to the strength of the structure an engineer should make the assessment.

Locating the steel in the concrete

To comply with Australian Standards.

Digital metal detector: BOSCH DMO 10. Use the detector to locate the steel in the concrete when positioning the ConcreteLink. This ensures steel is avoided when drilling.

Drilling the hole

Drill a 28mm hole to the depth required.

Preparing the hole

The hole must be moisture and dust free. Remove the dust using compressed air.

Installing the concrete insert

1. Recommended chemical anchor is Power-Fast epoxy injection adhesive gel.
2. Read instructions on product carefully.
3. The whole surface of the extended ConcreteLink unit in contact with the concrete must use sufficient adhesive gel as specified on the product.

Fitting the SafetyLink Stainless Steel Eyebolt

1. When screwing the locking hex nut onto the stainless steel eyebolt make sure it is fully screwed up exposing 30mm of thread, coat threads with Loctite.
2. Then screw the eyebolt into the spacer assembling the whole unit. Ensure the eyebolt is facing the right direction (refer to appendix diagram 1).
3. Use *lock tight* on the whole unit to ensure that the unit cannot be tampered with. (IMPORTANT NOTE: Before applying Loctite 243 use Loctite 7471 primer to activate the surface according to manufacturer's instructions).

Note: use the same procedure to install a SafetyLink Abseiling Eyebolt, SafetyLink Intermediate T Bolt, SafetyLink End Anchor Taper Bolt.

Testing for Free fall-arrest for one person: 15 kN ultimate strength

1. To comply with Australian Standards each ConcreteLink unit must be tested after installation.
2. Allow sufficient time at least 48 hours for curing before testing.
3. Test consists of ultimate pull out force proof loading to 50% of design purpose of anchorage.

Note: Drilled-in anchorages such as friction and glued-in anchorages shall be placed so that the shear load is at least twice the tension load. For collared eyebolts this translates to a pull at an angle not exceeding 20 degrees to the surface in which the bolt is installed.

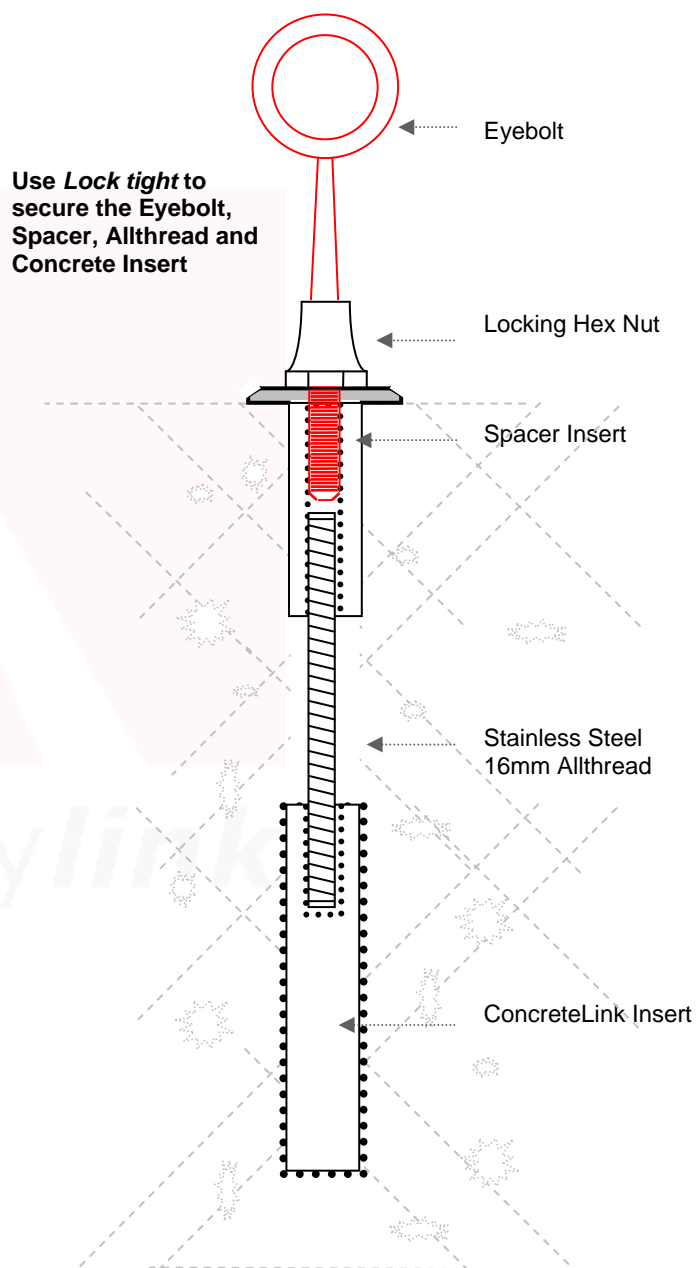

INSTALLATION: FOR MASONRY

All safety procedures must be complied with in accordance with the current safety code(s) of practice(s) for working at heights. Ensure safety at all times by being attached to anchor point approved safety equipment, using a scaffold or a secured ladder.

Positioning of SpacerLink Anchor Point (The pendulum effect still applies)

(refer to appendix diagram 2 and 3)

The first SpacerLink Anchor Point must be in a position easily reached by a secured ladder or a manhole access point.

⚠ During installation you must be safe at all times.

Positioning of SpacerLink

To comply with Australian Standards.

SpacerLink should not be positioned close to an edge

If any doubt exists as to the strength of the structure an engineer should make the assessment.

Preparation Tips

- Determine the distance that the anchor will be threaded through. Cut the threaded rod if necessary.
- Hammer Drill – stop hammering action on last section of concrete to prevent blowing out section.

Drilling the hole

1. Drill a pilot hole through the masonry.
2. Then drill a 25mm hole from either side if the wall to avoid damaging the wall.

Fitting the Stainless Steel Eyebolt

1. When screwing the locking hex nut onto the stainless steel eyebolt make sure it is fully screwed up exposing 30 mm of thread (coat threads with Loctite).
2. Use *lock tight* on the eyebolt, allthread and nut to ensure that the unit cannot be tampered with, (IMPORTANT NOTE: Before applying Loctite 243 use Loctite 7471 primer to activate the surface according to manufacturer's instructions).
3. Assemble the whole unit as shown then push the unit through the wall and fit the washer and nut.
4. Before tightening the nut turn the eyebolt to the direction required (Refer to appendix diagram 1).

Threads need to have a minimum of **six full 360° turns** into the ultimate thread.

Note: use the same procedure to install a SafetyLink Abseiling Eyebolt, SafetyLink Intermediate T Bolt, SafetyLink End Anchor Taper Bolt.

Testing for Free fall-arrest for one person: 15 kN ultimate strength

1. To comply with Australian Standards each SpacerLink unit must be tested after installation.
2. Test consists of ultimate pull out force proof loading to 50% of design purpose of anchorage.

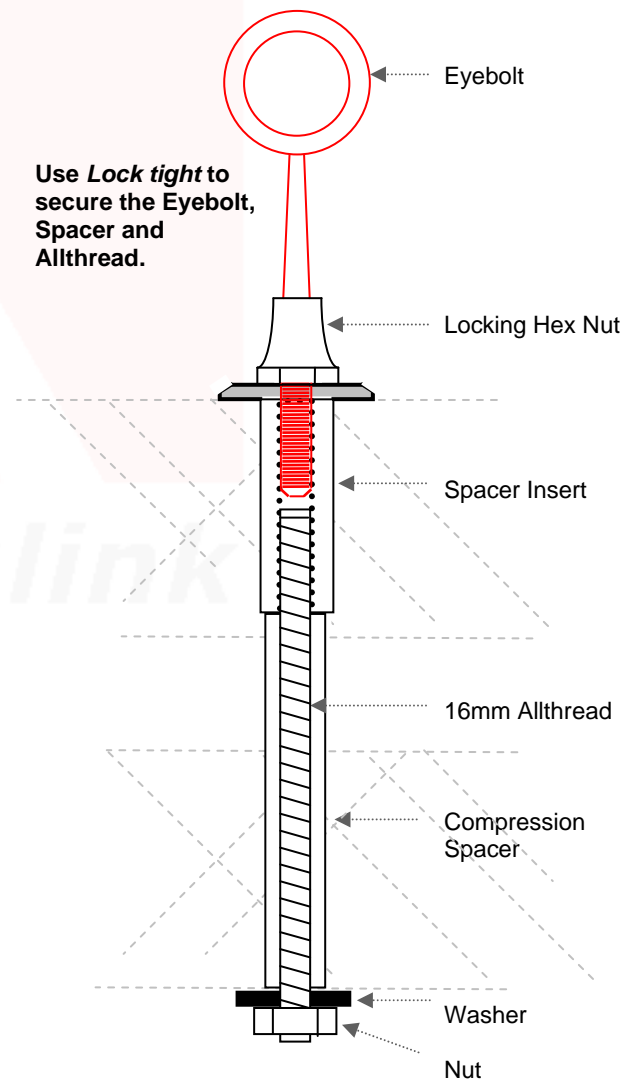



INSTALLATION: FOR MASONRY

All safety procedures must be complied with in accordance with the current safety code(s) of practice(s) for working at heights. Ensure safety at all times by being attached to anchor point approved safety equipment, using a scaffold or a secured ladder.

Positioning of SandwichLink Anchor Point (The pendulum effect still applies)

(refer to appendix diagram 2 and 3)

The first SandwichLink Anchor Point must be in a position easily reached by a secured ladder or a manhole access point. ⚠ During installation you must be safe at all times.

Positioning of SandwichLink

To comply with Australian Standards.

SandwichLink should not be positioned close to an edge

If any doubt exists as to the strength of the structure an engineer should make the assessment.

Preparation Tips

- Determine the distance that the anchor will be threaded through. Cut the threaded rod on SandwichLink if necessary.
- Hammer Drill – stop hammering action on last section of concrete to prevent blowing out section.

Drilling the hole

1. Drill a pilot hole through the masonry.
2. Then drill a 25mm hole from either side if the wall to avoid damaging the wall.

Fitting the Stainless Steel Eyebolt

1. When screwing the locking hex nut onto the stainless steel eyebolt make sure it is fully screwed up exposing 30 mm of thread, coat threads with Loctite (IMPORTANT NOTE: Before applying Loctite 243 use Loctite 7471 primer to activate the surface according to manufacturer's instructions).
2. Assemble the whole unit use *lock tight* on the SandwichLink Allthread and Spacer then push the unit through the wall and fit the eyebolt last.
3. Before tightening the locking hex nut, turn the eyebolt to the direction required (refer to appendix diagram 1).

Threads need to have a minimum of **six full 360° turns** into the ultimate thread.

Note: use the same procedure to install a SafetyLink Abseiling Eyebolt, SafetyLink Intermediate T Bolt, SafetyLink End Anchor Taper Bolt.

Testing for Free fall-arrest for one person: 15 kN ultimate strength

- To comply with Australian Standards each SandwichLink unit must be tested after installation.
- Test consists of ultimate pull out force proof loading to 50% of design purpose of anchorage.

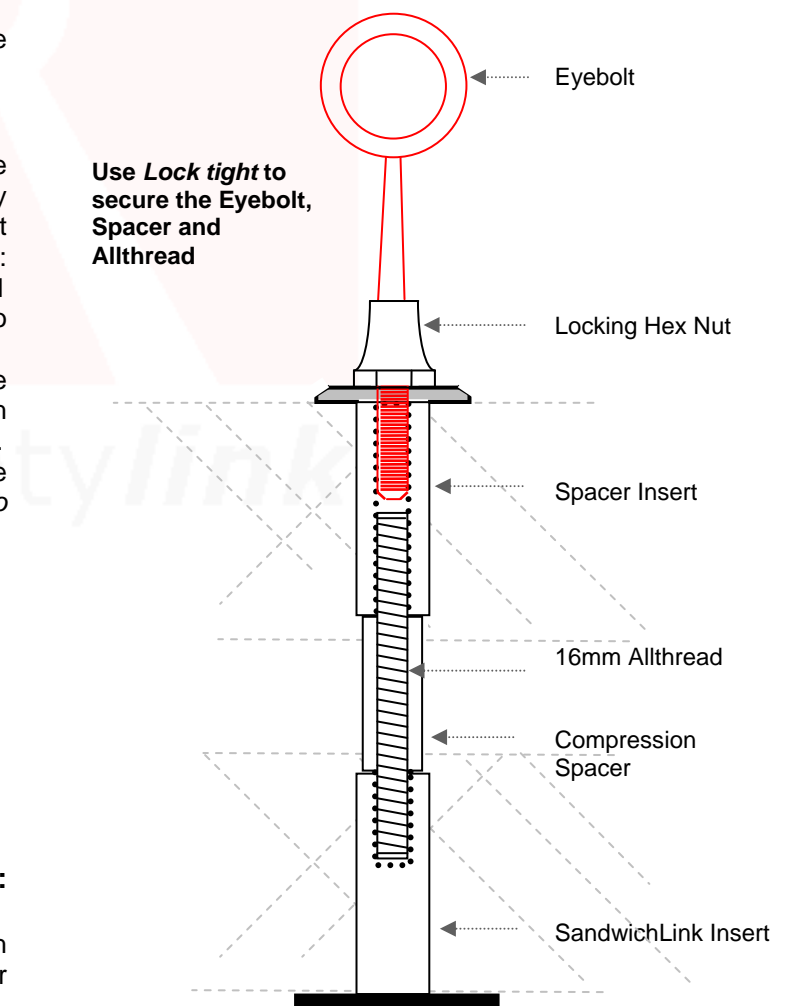



INSTALLATION: FOR MASONRY

All safety procedures must be complied with in accordance with the current safety code(s) of practice(s) for working at heights. Ensure safety at all times by being attached to anchor point approved safety equipment, using a scaffold or a secured ladder.

Positioning of SandwichLink Anchor (The pendulum effect still applies)

(refer to appendix diagram 2 and 3)

The first Anchor Point must be in a position easily reached by a secured ladder or a manhole access point.

⚠ During installation you must be safe at all times.

Positioning of SandwichLink

To comply with Australian Standards

SandwichLink should not be positioned close to an edge

If any doubt exists as to the strength of the structure an engineer should make the assessment.

Drilling the hole

- Drill a pilot hole through the masonry.
- Then drill a 25mm hole from either side of the wall to avoid damaging the wall.

Fitting the Stainless Steel Eyebolt

1. When screwing the locking hex nut onto the stainless steel eyebolt make sure it is fully screwed up exposing 30 mm of thread (coat threads with Locktite).
2. Push the SandwichLink through the underside of the roof.

Threads need to have a minimum of **six full 360° turns** into the ultimate thread.

Note: use the same procedure to install a SafetyLink Abseiling Eyebolt, SafetyLink Intermediate T Bolt, SafetyLink End Anchor Taper Bolt.

Waterproofing (apply only to a dry surface)

1. Use a sealant between the rubber washer and the roof sheeting to waterproof the roof.
2. Before tightening the locking hex nut, turn the eyebolt to the direction required (refer to appendix diagram 1).
3. Use **lock tight** on the eyebolt thread to ensure that the unit cannot be tampered with, (IMPORTANT NOTE: Before applying Loctite 243 use Loctite 7471 primer to activate the surface according to manufacturer's instructions).
4. Tighten using a spanner.

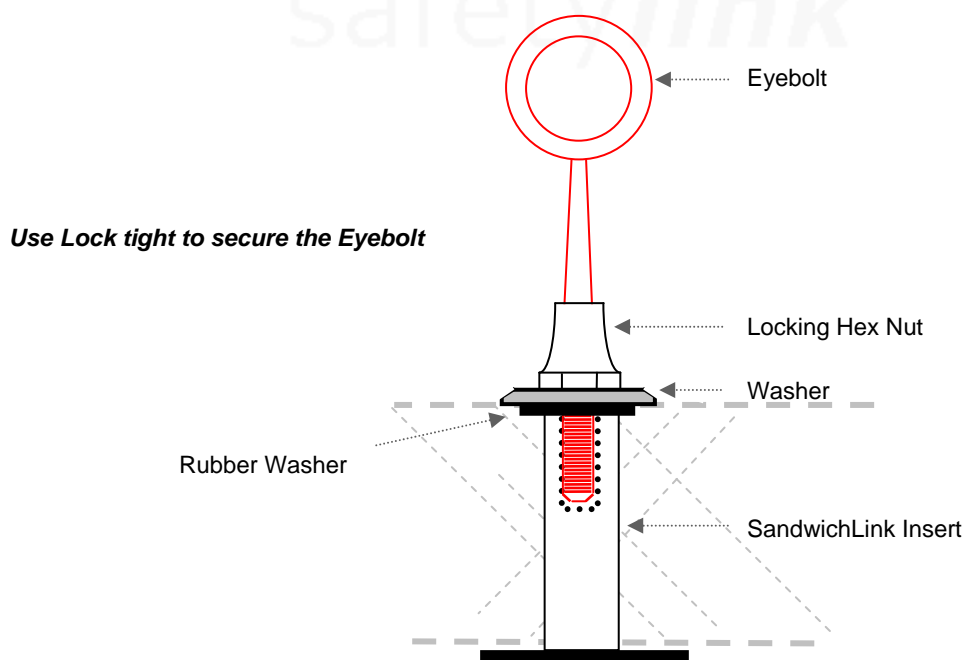



INSTALLATION: FOR RITECK ROOFING

All safety procedures must be complied with in accordance with the current safety code(s) of practice(s) for working at heights. Ensure safety at all times by being attached to anchor point approved safety equipment, using a scaffold or a secured ladder.

Positioning of SandwichLink Anchor (The pendulum effect still applies)

(refer to appendix diagram 2 and 3)

The first SandwichLink Anchor Point must be in a position easily reached by a secured ladder or a manhole access point.

⚠ During installation you must be safe at all times.

Positioning of SandwichLink

To comply with Australian Standards.

SandwichLink should not be positioned close to an edge

If any doubt exists as to the strength of the structure an engineer should make the assessment.

Drilling the hole

1. Drill a pilot hole through the Sandwich panel roof.
2. Then drill a 25mm hole from either side to avoid damaging the roof.

Fitting the Stainless Steel Eyebolt

1. When screwing the locking hex nut onto the stainless steel eyebolt make sure it is fully screwed up exposing 30 mm of thread, coat threads with Loctite, (IMPORTANT NOTE: Before applying Loctite 243 use Loctite 7471 primer to activate the surface according to manufacturer's instructions).
2. Push the SandwichLink through the underside of the roof.

Threads need to have a minimum of **six full 360° turns** into the ultimate thread.

Note: use the same procedure to install a SafetyLink Abseiling Eyebolt, SafetyLink Intermediate T Bolt, SafetyLink End Anchor Taper Bolt.

Waterproofing (apply only to a dry surface)

1. Use a sealant between the rubber washer and the roof sheeting to waterproof the roof.
2. Before tightening the locking hex nut, turn the eyebolt to the direction required (refer to appendix diagram 1).
3. Use *lock tight* on the eyebolt thread to ensure that the unit cannot be tampered with, (IMPORTANT NOTE: Before applying Loctite 243 use Loctite 7471 primer to activate the surface according to manufacturer's instructions).
4. Tighten using a spanner.

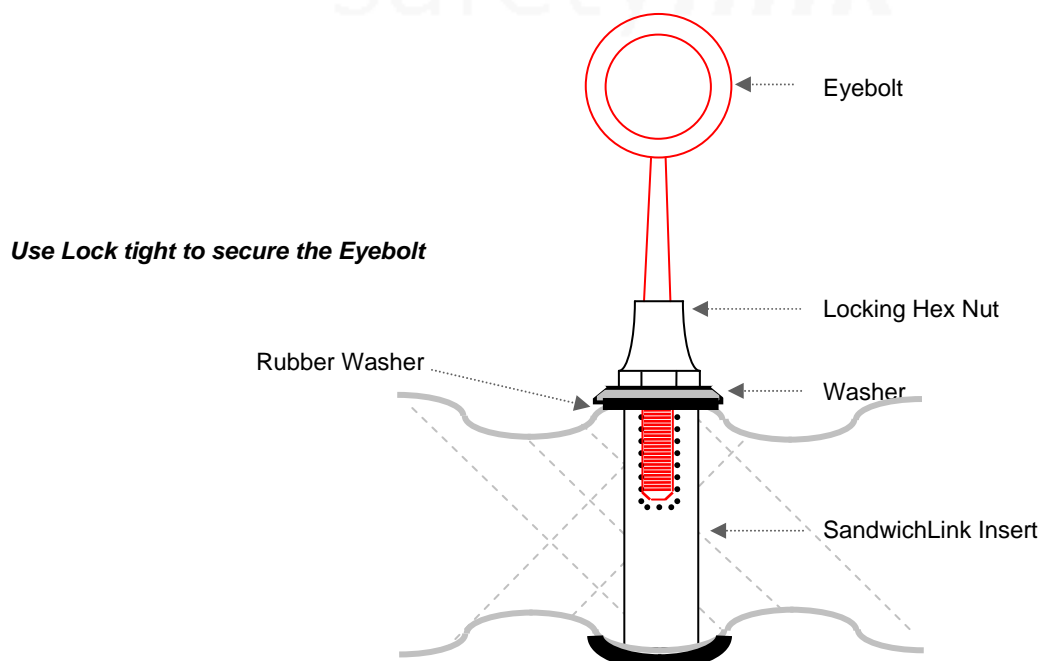
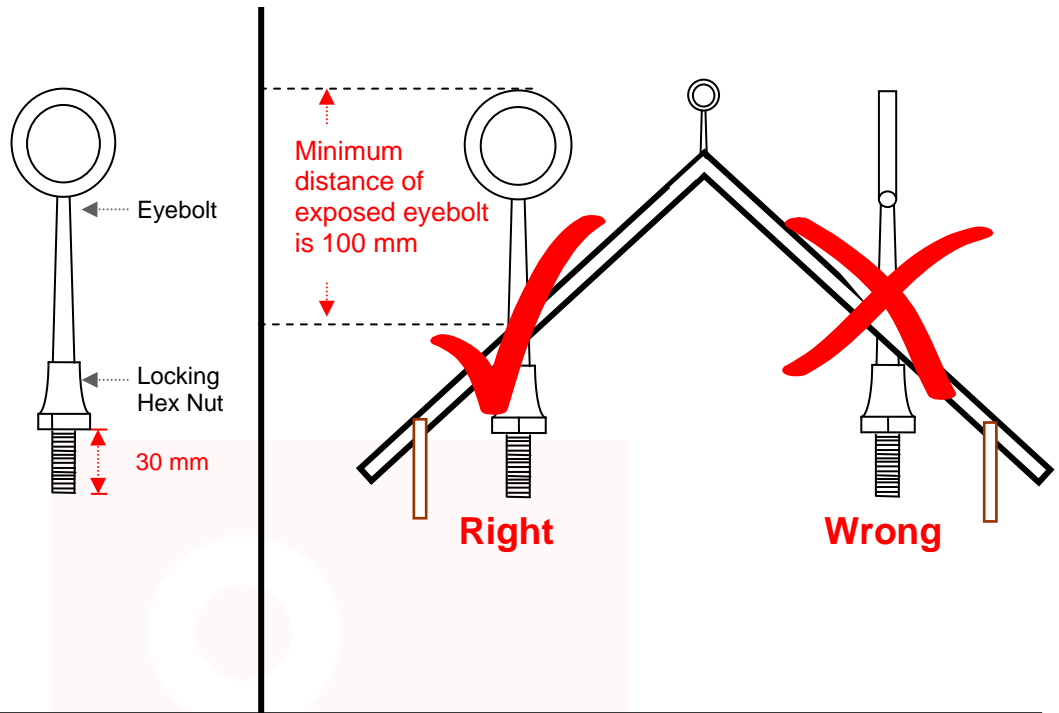

DIAGRAM 1 – CORRECT EYEBOLT LAYOUT :

Warning

Locking hex nut must be fully screwed up the thread of the eyebolt to expose 30mm of thread. This thread must be fully screwed into the bracket, coat threads with Loctite , (IMPORTANT NOTE: Before applying Loctite 243 use Loctite 7471 primer to activate the surface according to manufacturer's instructions)..

Locking hex nut must be firmly tightened onto the bracket to stop the eyebolt from unscrewing and to gain maximum strength.



Threads need to have a minimum of **six full 360° turns** into the ultimate thread.

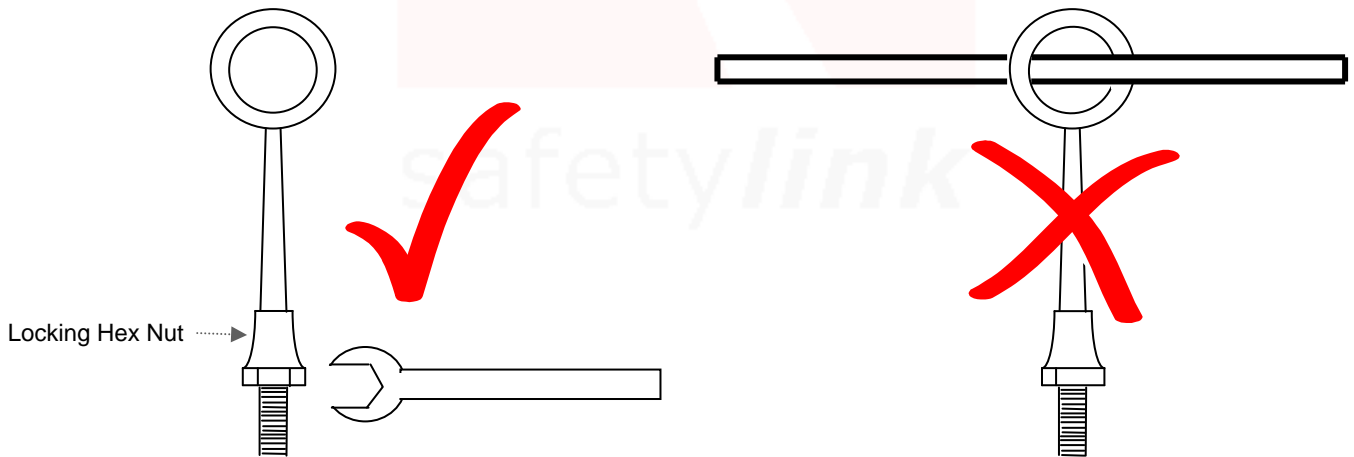

Right

Always use a spanner when tightening and un-tightening the locking hex nut.

Wrong

Do not place an object into the eye to tighten and un-tighten the locking hex nut, as this may damage the eyebolt.

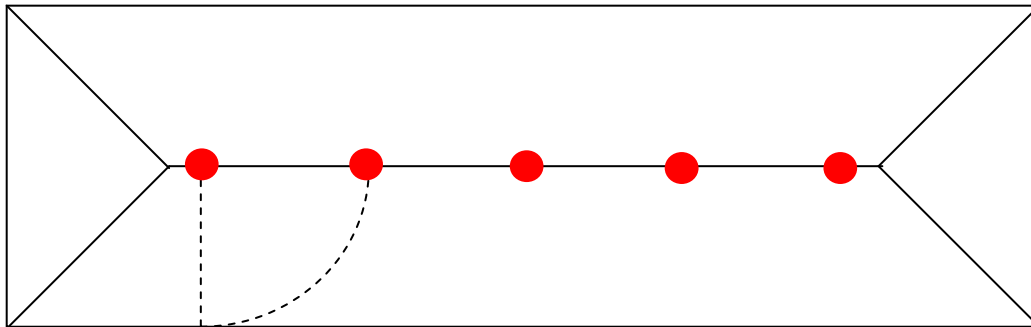

DIAGRAM 2 – POSITIONING LAYOUT :

THIS IS A GUIDE ONLY

All Safety procedures must be complied with when installing SafetyLink anchor points. For more information refer to WorkCover in regard to current safety code/s of practice/s for working at heights.

SafetyLink anchors are recommended to be six (6) metres apart. Spacing must be no greater than the rafter length. Please contact your distributor if you are unsure.



LADDER AND/OR ACCESS TO A ROOF

SafetyLink Anchor Points are placed by calculating the pendulum effect.

(The pendulum effect still applies to a flat concrete roof)

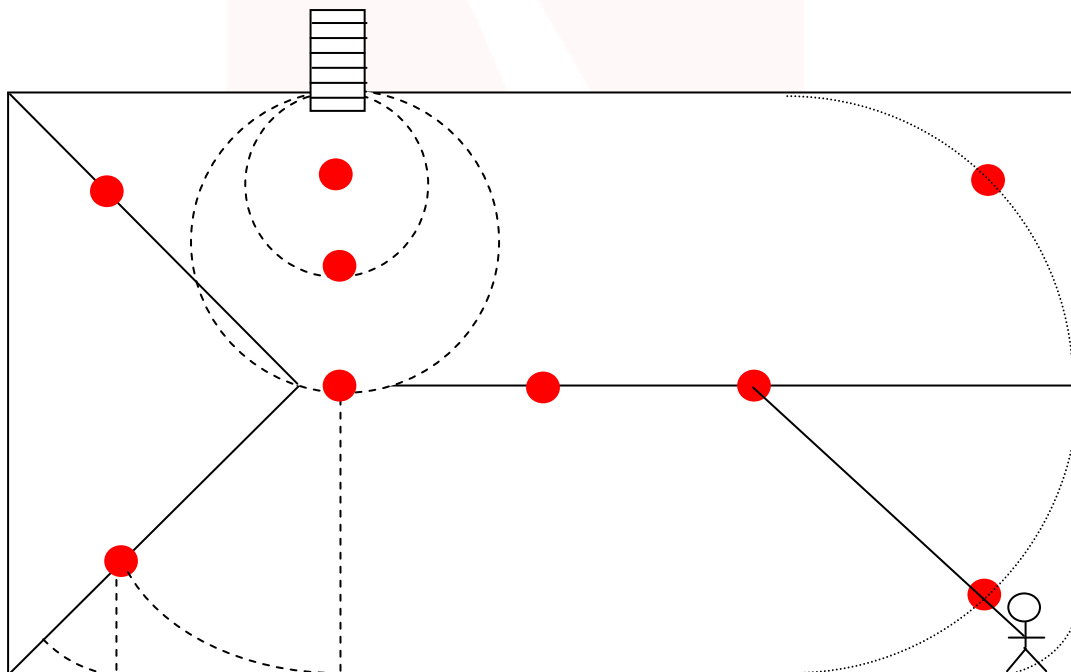

SafetyLink hip spacing must be no greater than the Rafter length measured from the hip.

SafetyLink is designed to withstand a drop force of 22.1kN in accordance with Test Specifications: Appendix G of AS/NZS 1891.1:1995.
Attach only to structure able to support the anchor point.

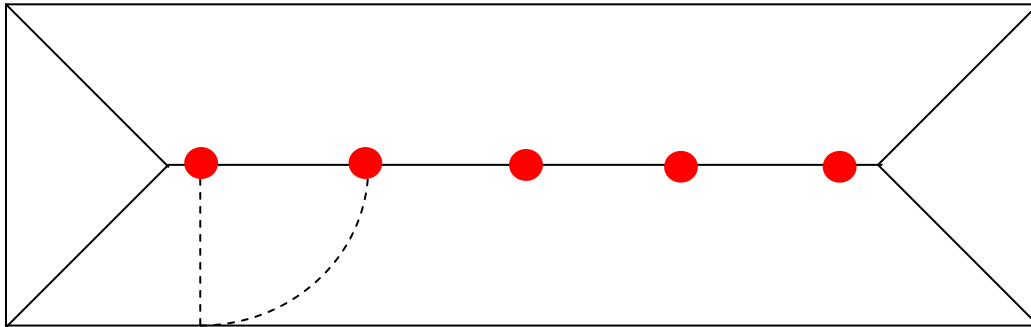

DIAGRAM 3 – POSITIONING LAYOUT :

THIS IS A GUIDE ONLY

All Safety procedures must be complied with when installing SafetyLink anchor points.
For more information refer to WorkCover in regard to current safety code/s of practice/s for working at heights.

SafetyLink anchors are recommended to be six (6) metres apart. Spacing must be no greater than the rafter length. Please contact your distributor if you are unsure.



LADDER AND/OR ACCESS TO A ROOF
SafetyLink anchor points are placed by calculating the pendulum effect.

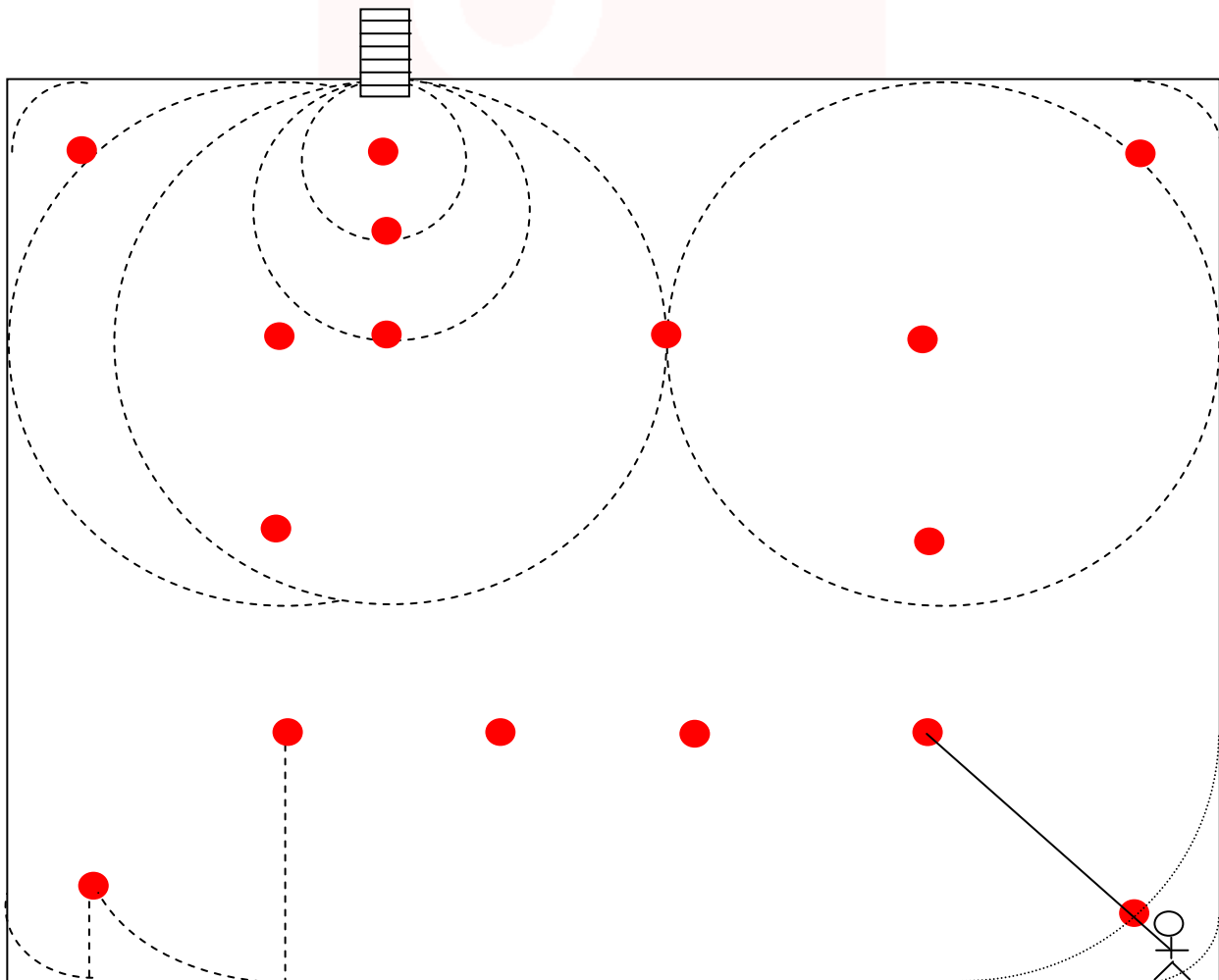

SafetyLink is designed to withstand a drop force of 22.1kN in accordance with Test Specifications: Appendix G of AS/NZS 1891.1:1995.
Attach only to structure able to support the anchor point.



DIAGRAM 4 – LATERAL BRACING STRAP :

Lateral bracing straps must be used if there is a possibility of falling in a direction 45 to 90 degrees to the rafter. Lateral Bracing Straps available from suppliers.

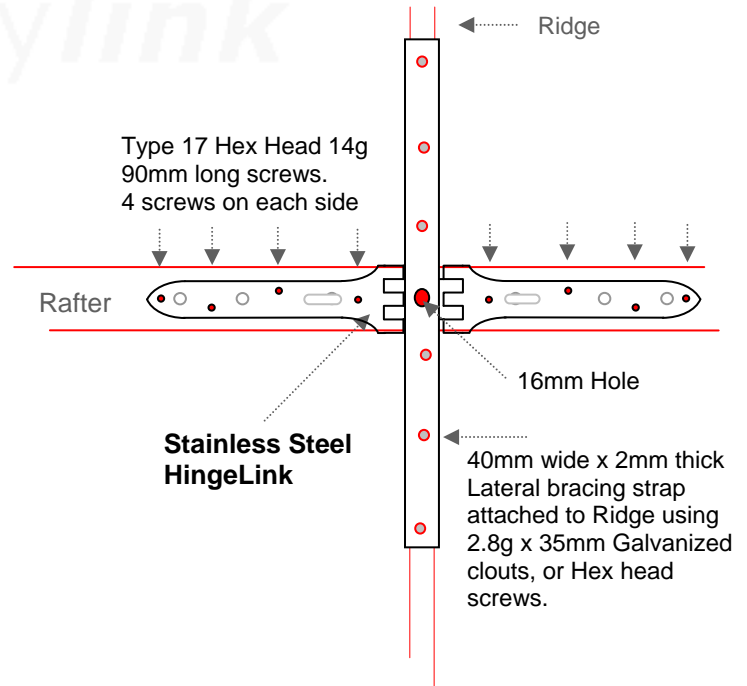
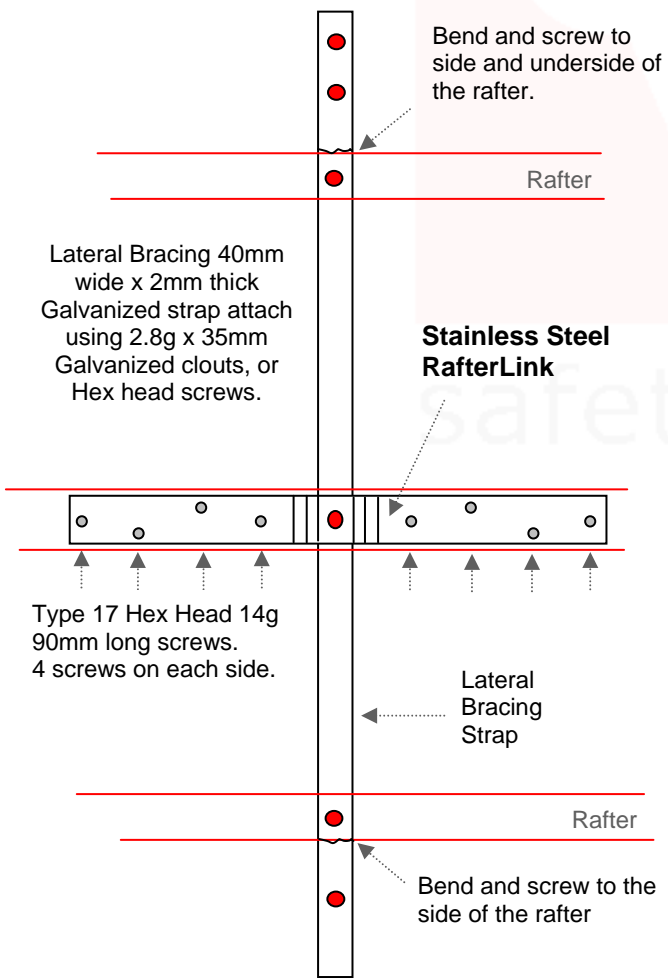
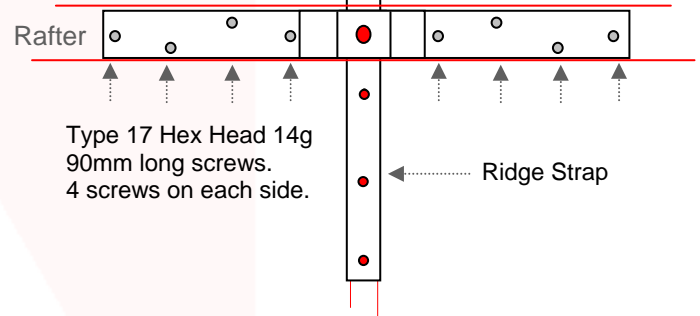
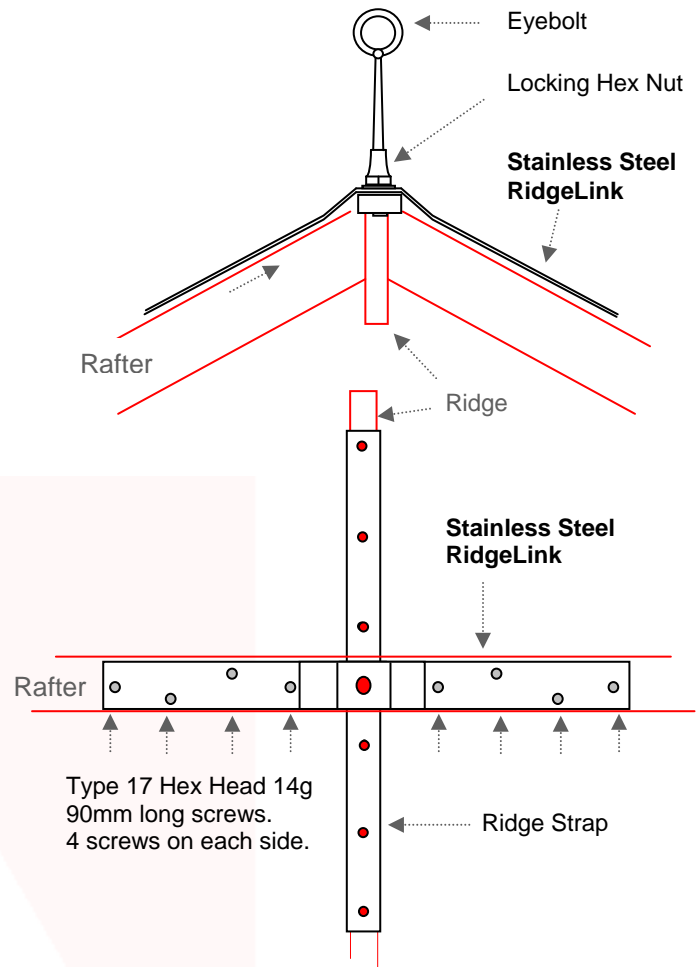
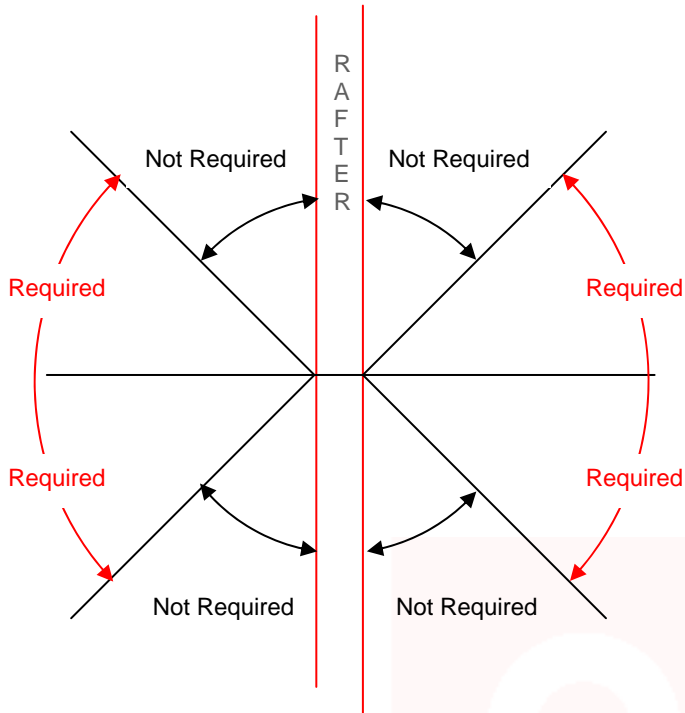



DIAGRAM 5 – POSITIONING HINGELINKS :

READ ALL INSTRUCTIONS CAREFULLY SOMEONE'S LIFE DEPENDS ON IT

Inspect the timber for splits, cracks, knots, white ant damage and to see how well the timber is secured to the structure. Attach anchors only to timber able to support the anchor point.

⚠ If any doubt exists as to the strength of the structure an engineer should make the assessment

STRENGTHEN THE HIPS

Strengthen hips by fixing a steel plate to the hip and down the rafters on either side sharing the load with the rafters

Trussed Hip

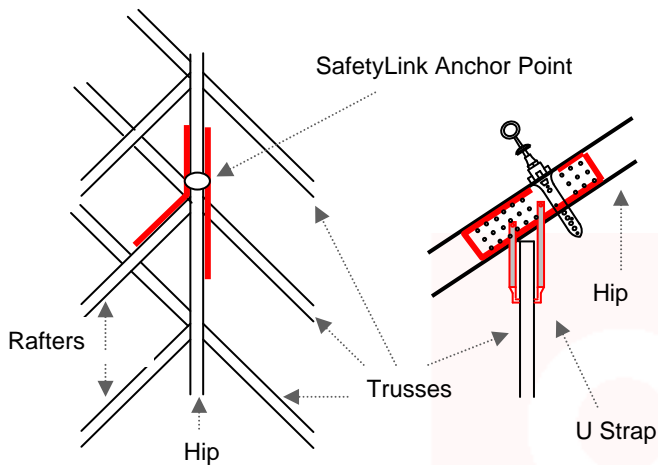

Pitched Hip

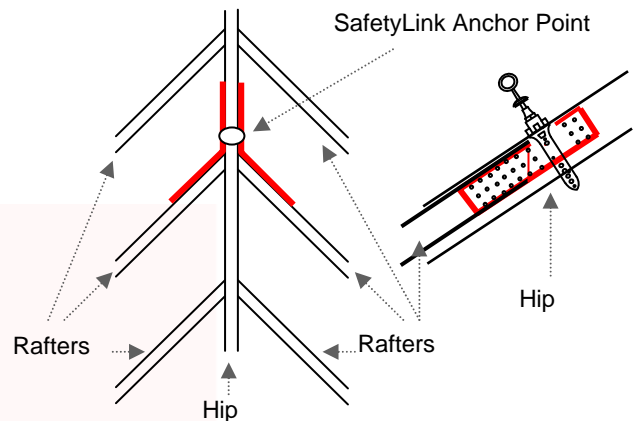

Lateral bracing Strap to Pitched Roof

1. Place the hoop iron strap along the ridge and screw the stainless steel anchor point through the strap.
2. Then screw the strap down onto the ridge giving HingeLink lateral strength.
3. Lateral bracing straps are available from suppliers.

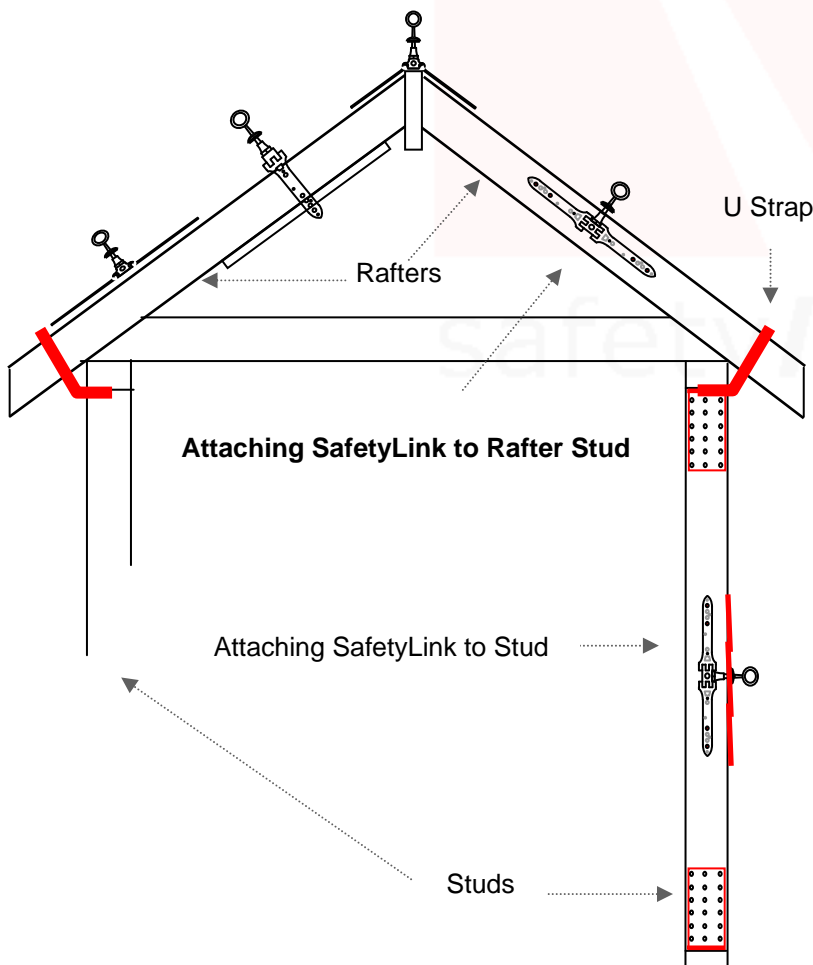

Lateral bracing Strap



Lateral Bracing 40mm wide x 2mm thick Galvanized Strap attach using 2.8g x 35mm Galvanized Clouts, or Hex Head Screws.

U TYPE HOLDING DOWN STRAPS

May be required to secure rafters or trusses down.

U Strap

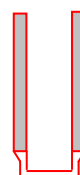

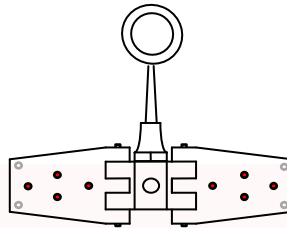
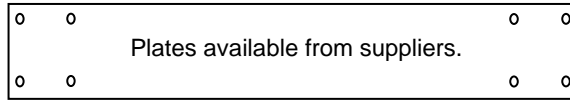

DIAGRAM 6 – STRENGTHENING RAFTER PLATES :

SafetyLink fixed to the side of Timber Studs, Rafters, Purlins or Beams

Use 2 steel plates one on either side of timber.

Secure by using 8 only 2.8g x 35mm Galvanized clouts each side.



Plates available from suppliers.

Use 8 type 8mm mild steel bolts with washers on both ends of the bolts to fix the SafetyLink.

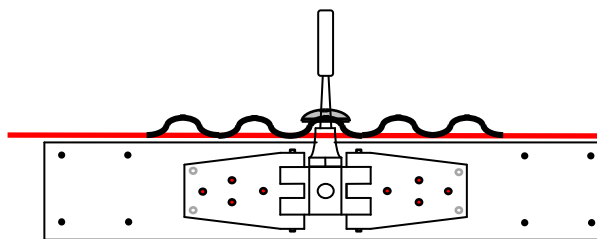
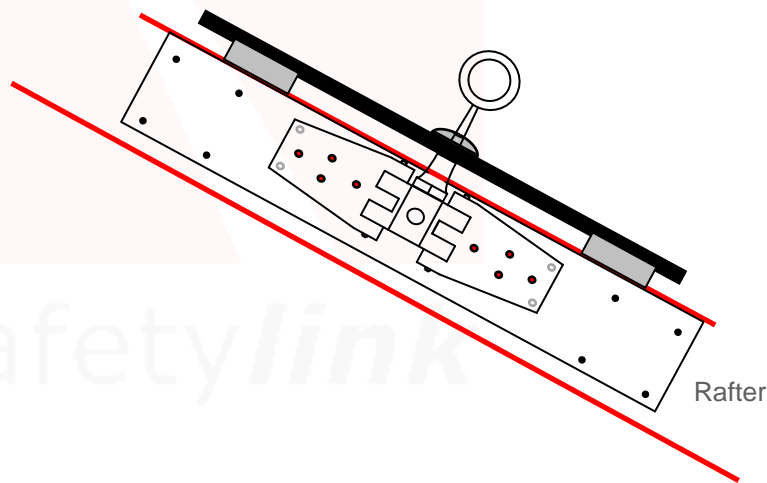
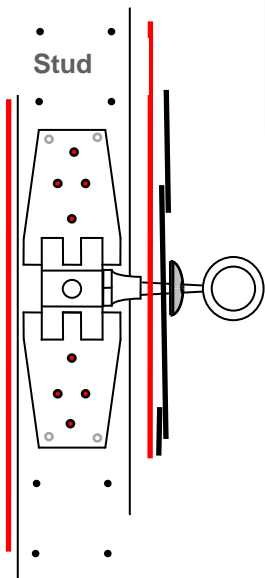

**Timber Purlins and Beams
Must be certified by an engineer.**

With all applications timber must be securely fastened to the structure.



DIAGRAM 7 – HINGELINK UNIT :



Energy absorbing batten designed to strengthen the rafter screwed at either end using 12g 50mm hex head screws.

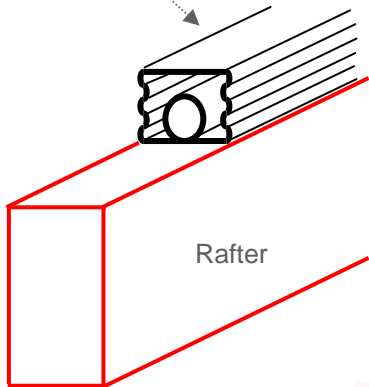

Stainless Steel HingeLink

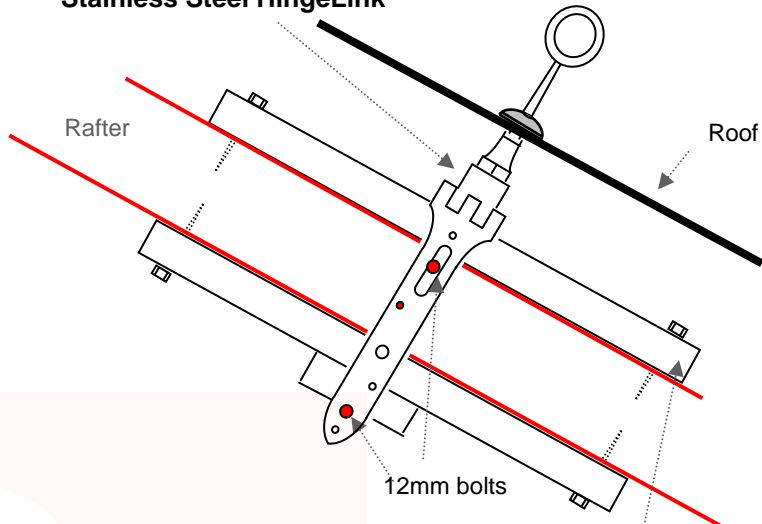

Energy absorbing batten designed to strengthen the rafter.

Stainless Steel HingeLink

Energy absorbing batten designed to strengthen the rafter.

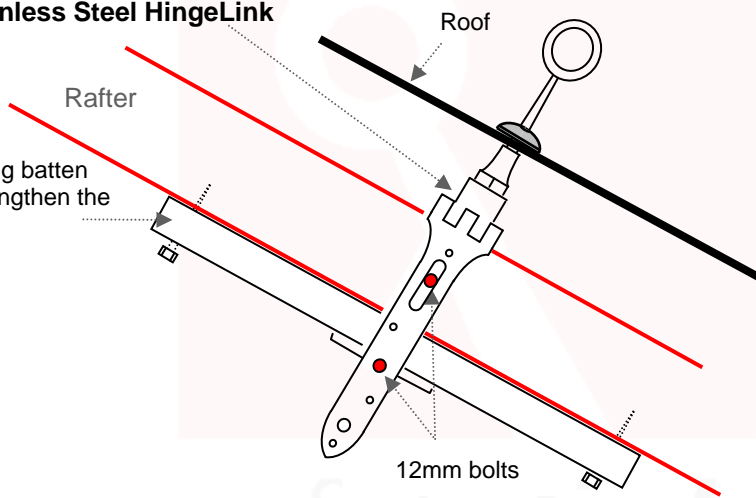

Stainless Steel HingeLink

The amount of gang nail plates required depends on the strength of the rafter.

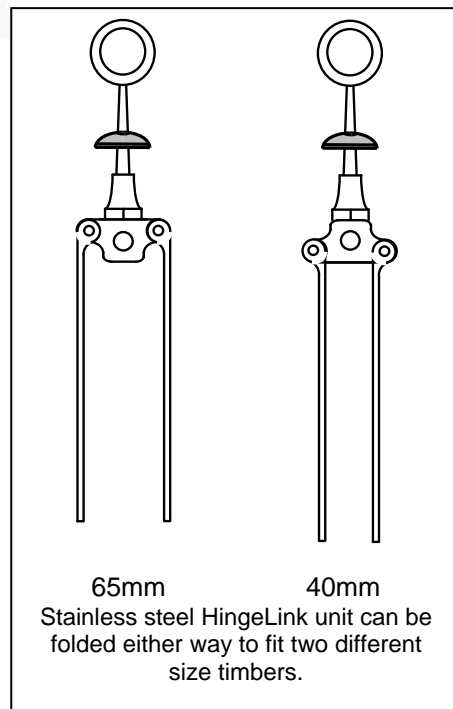
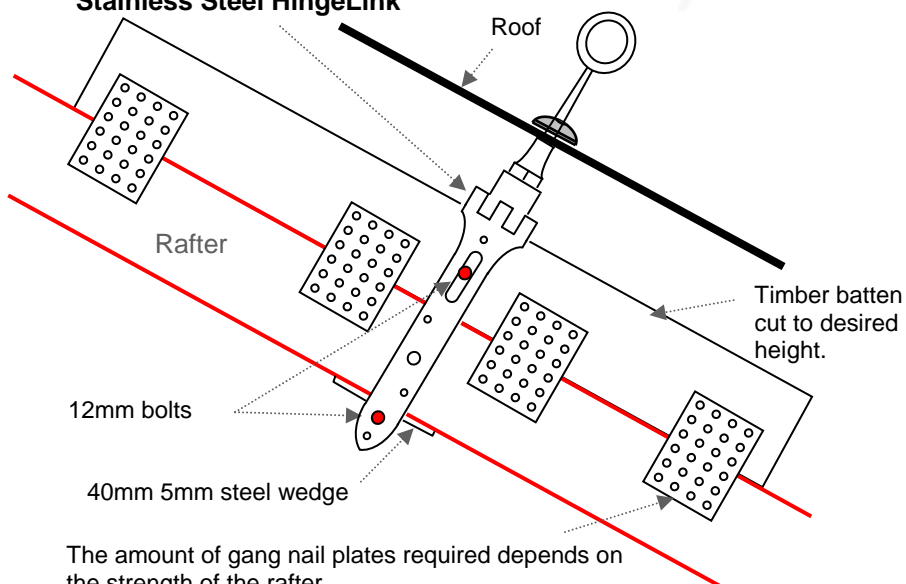

IN CASE OF ACCIDENT

⚠ A FALL RESCUE PLAN SHOULD BE DEVELOPED PRIOR TO USING SAFETYLINK EQUIPMENT.

⚠ Persons working at heights should not work alone.

It is critical that before using any SafetyLink Systems a fall rescue plan is in place for any persons suspended mid-air following a fall. Serious injury or death can occur in a matter of minutes, particularly if a person's movement or breathing is restricted or loss of consciousness has occurred. In accordance with your fall rescue plan and appropriate first aid procedures it is essential to remove the person from the suspended position as quickly as possible.

In accordance with AS/NZS 1891.4:2000 clause 9.5

EQUIPMENT WHICH HAS ARRESTED A FALL OR SHOWS A DEFECT

Any piece of equipment including both personal and permanently installed items, which has been used to arrest a fall or which shows any defect during operator or periodic inspection shall be withdrawn from service immediately and a replacement obtained if necessary. A label indicating the condition or defect should be attached to the equipment, and it should be examined by a competent person who will decide whether the equipment is to be destroyed or repaired if necessary and returned to service. In the latter case, details of any repair shall be documented and a copy given to the operator.



DISTRIBUTOR:

www.heightsafety.com