



safetylink™

INSTALLATION HANDBOOK:
HORIZONTAL STATICLINE

RetroLink Tube
Installation to Roof Sheet Surface
(SINGLE END)



READ ENTIRE HANDBOOK BEFORE INSTALLING ANY SAFETYLINK PRODUCT.

ALL PRODUCTS MUST BE INSTALLED IN ACCORDANCE WITH SAFETYLINK'S INSTALLATION HANDBOOK, USING ONLY PRODUCTS SUPPLIED BY SAFETYLINK PTY LTD.

FAILURE TO FOLLOW ALL WARNINGS AND INSTRUCTIONS MAY RESULT IN A SERIOUS INJURY OR DEATH.

If you are uncertain and need help please email: safetylink@heightsafety.com.au
Phone: +61 249 972272 | Freecall: 1800 972272 | Fax: +61 249 971104
or visit our website www.heightsafety.com



INSTALLATION OF A SAFETYLINK STATICLINE SYSTEM USING RETROLINK TUBE ON ROOF SHEET SURFACE

	PAGE
WARNINGS: INSTALLATION AND USE	3
MAINTENANCE: PERIODIC INSPECTIONS	4
WARRANTIES:	5
BELOW 25 DEGREES – SINGLE END ASSEMBLY	
COMPONENTS	6
INSTALLATION	7-8
BELOW 25 DEGREES – INTERMEDIATE ASSEMBLY	
COMPONENTS	9
INSTALLATION	10-11
BELOW 25 DEGREES – SINGLE CORNER ASSEMBLY	
COMPONENTS	12
INSTALLATION	13-14
STATICLINE SYSTEM INSTALLATION	
INSTALLATION	15
TIGHTENING TORQUE FOR SWAGELESS TERMINALS	15
EXAMPLE OF STATICLINE LAYOUT	16
NOTES	17
IN CASE OF AN ACCIDENT:	18





WARNINGS

READ CAREFULLY SOMEONE'S LIFE DEPENDS ON IT

- The building or structure for the anchorages should be assessed by an engineer, unless it is clear to a competent person that the structure is adequate.
- All safety procedures must be complied with in accordance with the current safety code(s) of practice(s) for working at heights. Ensure safety at all times by being attached to anchor point approved safety equipment, using a scaffold or a secured ladder.
- Installation is to be carried out by, or under the supervision of a competent person.
- To prevent galling use a spray can of nickel anti-seize.
- Recommended waterproofing for roof tiles: *Sika Flex Co-Polymer Sealant*.
- Recommended waterproofing for metal roof: *Silicone Sealant*.
- All threads must be coated with Loctite prior to assembly. (IMPORTANT NOTE: Before applying Loctite 243 use Loctite 7471 primer to activate the surface according to manufacturer's instructions).
- SafetyLink StaticLine's must be installed to roofs below 25 degrees.

WARNING: RetroLink Anchors should be positioned 2 metres from the edge on Cliplock roofs.

-  **Maximum user per system is Four (4).**
-  **Maximum person per span is Two (2).**
-  **See system information for site specific use.**

WARNING

Locking Hex Nut must be fully screwed up the thread of the Intermediate T-Bolt to expose 30mm of thread. This thread must be fully screwed into the Retro Tube.

(Loctite must be used on all threads).

Locking Hex Nut must be firmly tightened onto the Retro Tube to stop the Intermediate T Bolt from unscrewing and the gain maximum strength.

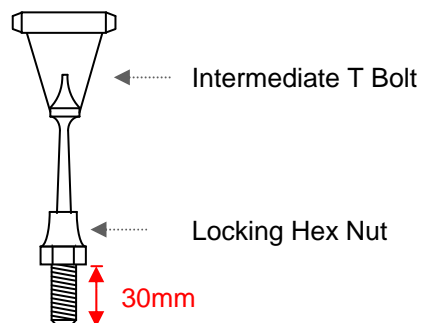



MAINTENANCE – PERIODIC INSPECTIONS

All items of equipment which are in regular use shall be subjected to periodic inspection and servicing.

These regular scheduled inspections and servicing must be carried out by a competent person (*refer to AS/NZS 1891.4:2000 section 9 if clarification required or contact SafetyLink*).

SafetyLink Anchorages (*In accordance with AS/NZS 1891.4:2000 clause 9.3.3 and 9.3.5*)

ALL ANCHORAGES MUST BE INSPECTED EVERY 12 MONTHS.

Procedures to be followed at inspection time:

- Visually inspect anchors for signs of deterioration.
- The End Anchor and Intermediate T Bolts should remain straight, a bent End Anchor or Intermediate T Bolt will indicate that the StaticLine has arrested a fall (*The design features of the End Anchor and Intermediate T Bolts includes the ability to bend like a fishing pole starting from the top and working its way to the bottom, enabling it to use up energy as the Anchor bends whilst lessening the force on the person falling and the attachment point*).
- Visually inspect the components of the anchor for corrosion, superficial surface marking is permitted while deeper corrosion or pitting would require attention.
- Manually (by hand) check the End Anchor and Intermediate T Bolt for rigidity and tightness, if the End Anchor and Intermediate T Bolt can turn in the anticlockwise direction it will require attention.
- Visually inspect the attachment component of the anchorage where practically possible.
- Visually inspect the parent structure for modifications or deterioration which might lead to loss of anchorage strength.
- Check the condition of line tensioners.
- Check for any evidence of wear, cuts, looseness, extension, interstrand wear, corrosion, stiffness, brittleness or fraying of the steel cable.
- Check the integrity of cable terminations.
- Check for the presence of contaminants or exposure to a corrosive or extreme environment which could significantly reduce the working load of the StaticLine.
- Run the SafeLink Shuttle along the length of the line to verify its correct function.

IN ADDITION TO SAFETYLINK PTY LTD EQUIPMENT, ALL ANCILLARY EQUIPMENT MUST BE INSPECTED IN ACCORDANCE WITH APPLICABLE REGULATORY REQUIREMENTS AND THE MANUFACTURER'S INSTRUCTIONS.



FOR MAINTENANCE ADVICE AND SERVICES PLEASE CONTACT SAFETYLINK ON 0249 972272 OR 1800 972272 FOR YOUR NEAREST SAFETYLINK INSPECTION SERVICE CENTRE OR EMAIL: safetylink@heightsafety.com.au

To download Installation Manuals on other SafetyLink products please visit our website at www.heightsafety.com



EXTRACT: SafetyLink Pty Ltd STANDARD TERMS AND CONDITIONS

- 11.1 To the extent permitted by law all implied conditions, warranties and undertakings are expressly excluded.
- 11.2 Except as provided in this clause the Company shall not be liable for any loss or damage, whether direct or indirect (including consequential losses or damage) arising out of any breach of contract by the Company or any negligence of the Company, its employees or agents.
- 11.3 Should the Company be liable for a breach of a guarantee, condition or warranty implied by the Australian Consumer Law (not being a guarantee, condition or warranty implied by sections 51, 52 and 53 of that Law) then its liability for a breach of any such condition or warranty express or implied shall be limited, at its option, to any one or more of the following.
- A) in case of Goods
- (I) the replacement of the Goods or the supply of equivalent Goods.
- (II) the repair of the goods,
- (III) the payment of the cost of replacing the Goods or acquiring equivalent Goods.
- (IV) The payment of the cost of having the Goods repaired.
- Provided that any such Goods are returned to the Company by the Purchaser at the Purchaser's expense.
- B) in the case of services
- (i) the supply of the services again,
- (ii) the payment of the cost of having the services supplied again.
- 11.4 The Company will not be liable for the costs of recovery of the Goods from the field, loss of use of the Goods, loss of time, inconvenience, incidental or consequential loss or damage, nor for any other loss or damage of her than as stated above, whether ordinary or exemplary, caused either directly or indirectly by use of the Goods.
- 11.5 The Company warrants that at the time of shipment, Products manufactured by it will be free from defects in material and workmanship. In the absence of a modified written warranty, the Company agrees to making good any such defects by repairing the same or at the Company's option by replacement, for a period of (1) one year from the date of shipment. This limited warranty applies provided that:
- (a) defects have arising solely from faulty materials or workmanship;
- (b) the Products have not received maltreatment, inattention or interference;
- (c) **the Products have been installed in accordance with the Company's Installation Handbooks using only products supplied by the Company;**
- (d) accessories used with the Products are manufactured by or approved by the Company ;
- (e) the Products are maintained in accordance with Australian Standard 1891.4 (section 9).
- (f) you notify any claim under this warranty to SafetyLink in writing to the address below no later than 14 days after the event or occurrence concerning the produce giving rise to the claim and you pay all costs related to your claim.

This warranty does not apply to any defects or other malfunctions caused to the Goods by accident, neglect, vandalism, misuse, alteration, modification or unusual physical, environment or electrical stress.

Please note that the benefits to the purchaser (as a consumer) given by this warranty are in addition to your other rights and remedies under the Australian Consumer Law. Our goods come with guarantees that cannot be excluded under the Australian Consumer Law. You are entitled to a replacement or refund for a major failure and compensation for any other reasonably foreseeable loss or damage. You are also entitled to have the goods repaired or replaced if the goods fail to be of acceptable quality and the failure does not amount to a major failure.

- 11.6 If any goods are not manufactured by the Company, the guarantee of the manufacturer thereof shall be accepted by the Purchaser as the only express warranty given in respect of the goods.
- 11.7 Except as provided in this clause 11, all express and implied warranties, guarantees and conditions under statute or general law as the merchantability, description, quality, suitability or fitness of the Products for any purpose or as to design, assembly, installation, materials or workmanship or otherwise are hereby expressly excluded (to the extent to which they may be excluded by law).

PLEASE SEE SAFETYLINK PTY LTD FULL STANDARD TERMS OF CONDITIONS OF SALE FOR FURTHER REFERENCE.



INSTALLATION OF A SAFETYLINK STATICLINE SYSTEM USING RETROLINKS ON ROOF SHEET SURFACE BELOW 25 DEGREES

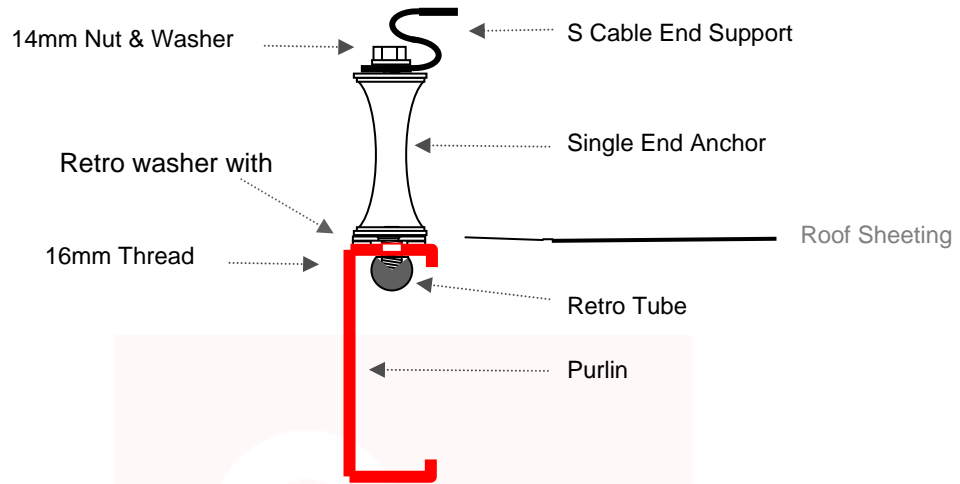

COMPONENTS:

14 mm Nuts



14 mm Spring Washers



S Cable End Support



Single End Anchor Absorbing Bolt



Retro washer with rubber



Tightening Cables with Plastic Washer & Retro Tube

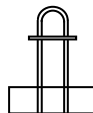

INSTALLATION: ROOF SHEET BELOW 25 DEGREES

 During installation you must be safe at all times.

Inspect the steel for strength

Inspect how well the steel purlin is secured to the structure. Minimum steel purlin gauge 1.2mm.

 If any doubt exists as to the strength of the structure an engineer should make the assessment.

Locating the Purlin

If the roof is screwed through the roof sheets simply follow the screws. If the roof sheeting has concealed fixings, finding the purlin is more difficult. You can lift a sheet to find the purlin or by walking on the roof you can feel the purlin. You can also use a strong magnet to find the purlin.

 During installation you must be safe at all times.

After locating Purlin

1. Locate the centre of the purlin and drill a 25mm hole.

After drilling 25mm hole in purlin

2. Hold onto the positioning ties and slide the Retro Tube vertically through the 25mm hole. Once the tube is through the hole, reorientate it to a horizontal position.

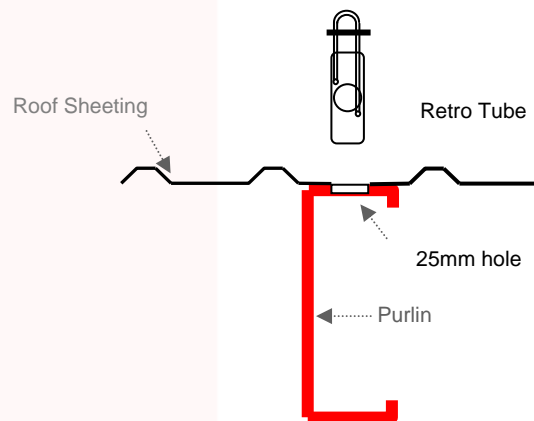

3. Slide the plastic washer down the positioning ties and draw the Retro Tube up to the underside of the purlin.

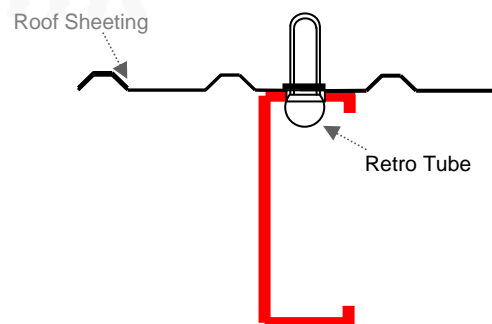



RETROLINK TUBE - SINGLE END ASSEMBLY

Product Code: STAT.RETRO003

- Coat around the plastic washer with silicone, then place the retro washer with rubber in a central location over the plastic washer.

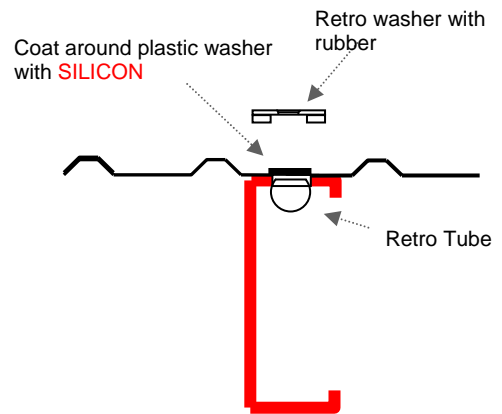

- Apply silicone around the centre of the washer, to seal between Single End Anchor and Retro washer with rubber.

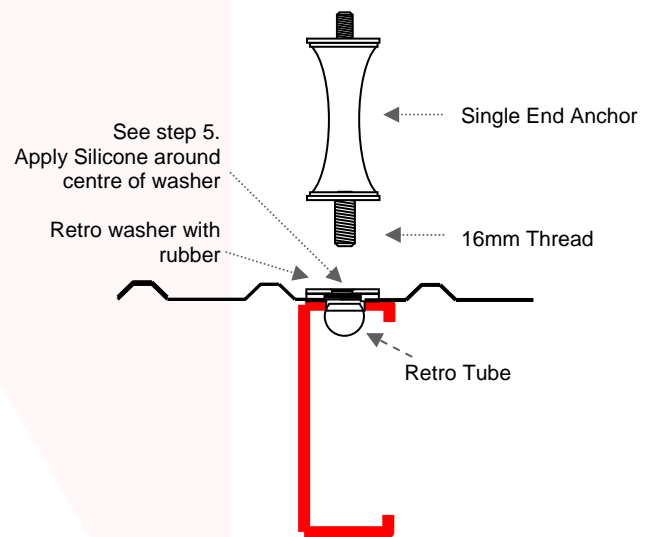

- Screw the Single End Anchor into the Retro Tube. Install the S Cable End Support and tighten the 14mm nut and spring washer whilst tightening the Single End Anchor into the tube making certain the S Cable End Support lines up with the run of the StaticLine. **Use Loctite on all threads.** (IMPORTANT NOTE: Before applying Loctite 243 use Loctite 7471 primer to activate the surface according to manufacturer's instructions).

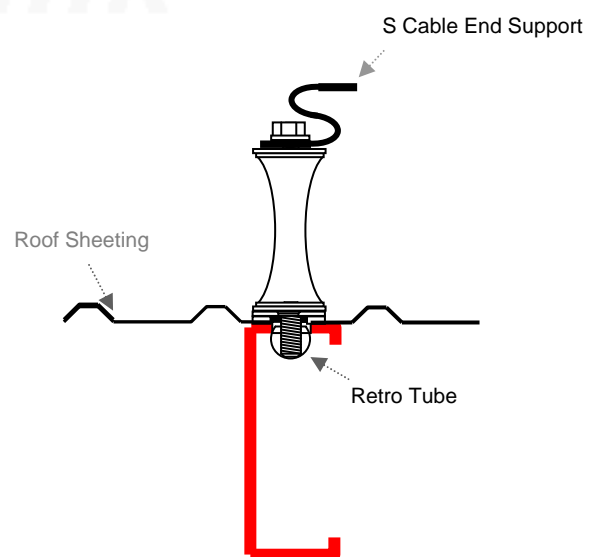

Note: Threads need to have a minimum of **six full 360° turns** into the ultimate thread.



RETROLINK TUBE – INTERMEDIATE ASSEMBLY

Product Code: STAT.RETRO004

INSTALLATION OF A SAFETYLINK STATICLINE SYSTEM USING RETROLINKS ON ROOF SHEET SURFACE BELOW 25 DEGREES

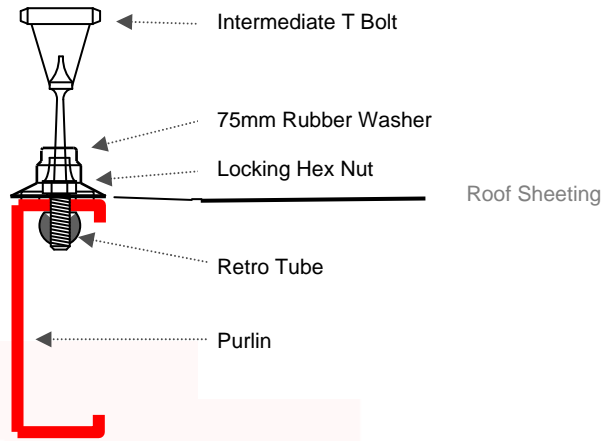

COMPONENTS:

Intermediate T Bolt



75mm Rubber Hat Washer



Locking Hex Nut



Retro washer with rubber



Plastic Washer, Tightening Cables & Retro Tube

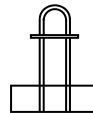



RETROLINK TUBE – INTERMEDIATE ASSEMBLY

Product Code: STAT.RETRO004

INSTALLATION: ROOF SHEET BELOW 25 DEGREES

⚠ During installation you must be safe at all times.

After locating Purlin

1. Locate the centre of the purlin and a drill 25mm hole.

After drilling 25mm hole in purlin

2. Hold onto the positioning ties and slide the Retro Tube vertically through the 25mm hole. Once the tube is through the hole, reorientate it to a horizontal position.

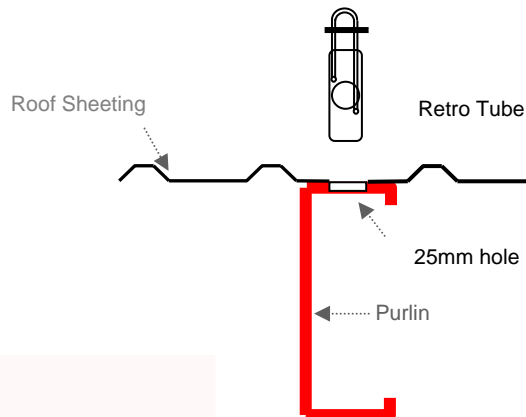

3. Slide the plastic washer down the positioning ties and draw the Retro Tube up to the underside of the purlin.

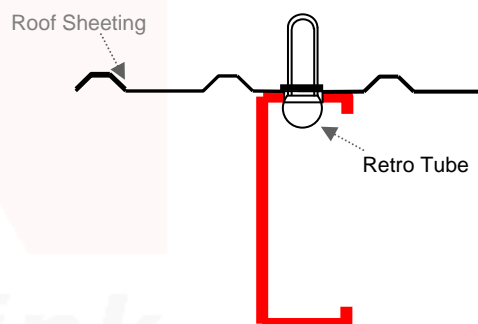

4. Coat around the plastic washer with silicone, then place the retro washer with rubber in a central location over the plastic washer.

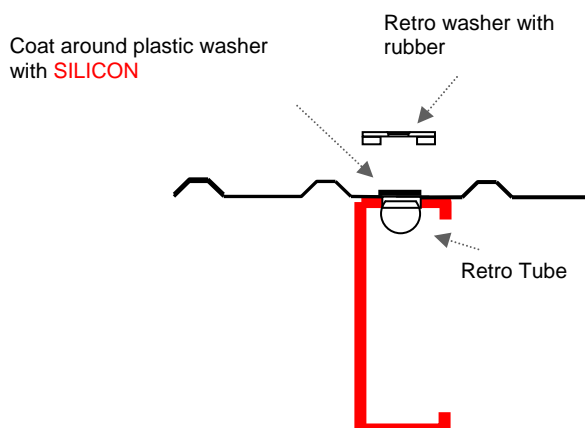



INSTALLATION: Continued ...

Note: Threads need to have a minimum of **six full 360° turns** into the ultimate thread.

4. Screw Intermediate T Bolt into Retro Tube, tightening locking hex nut in required direction.

Loctite must be used on all threads.
(IMPORTANT NOTE: Before applying Loctite 243 use Loctite 7471 primer to activate the surface according to manufacturer's instructions).

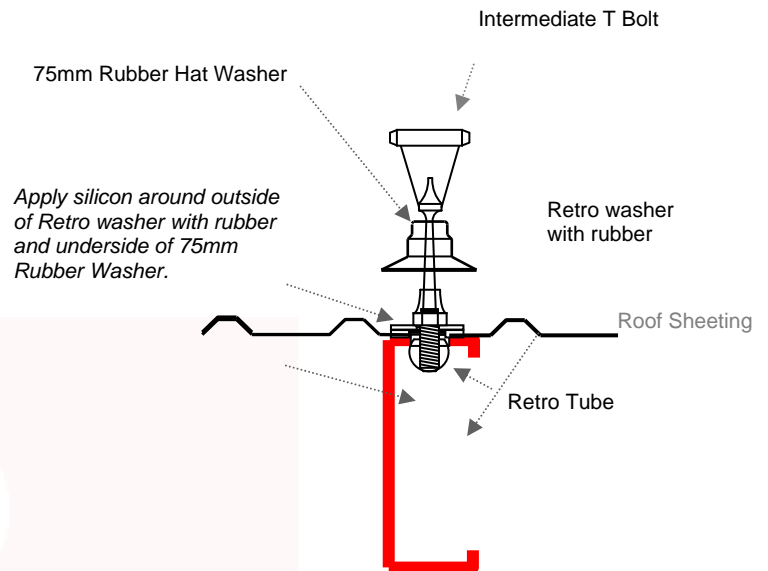

5. Apply silicon around the outside of the Retro washer with rubber and the underside of the 75mm Rubber Hat Washer. Push the 75mm Rubber Hat Washer down over the applied silicone.

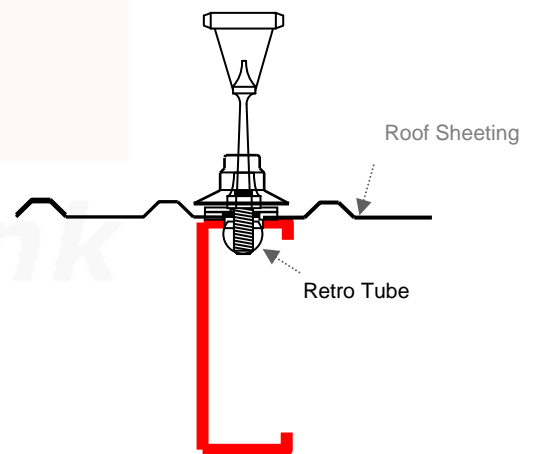

Inspect the steel for strength.

Intermediate T Bolts must be spaced at maximum 10 metres apart.

⚠ If any doubt exists as to the strength of the structure an engineer should make the assessment.

⚠ During installation you must be safe at all times.



INSTALLATION OF A SAFETYLINK STATICLINE SYSTEM USING RETROLINKS ON ROOF SHEET SURFACE BELOW 25 DEGREES

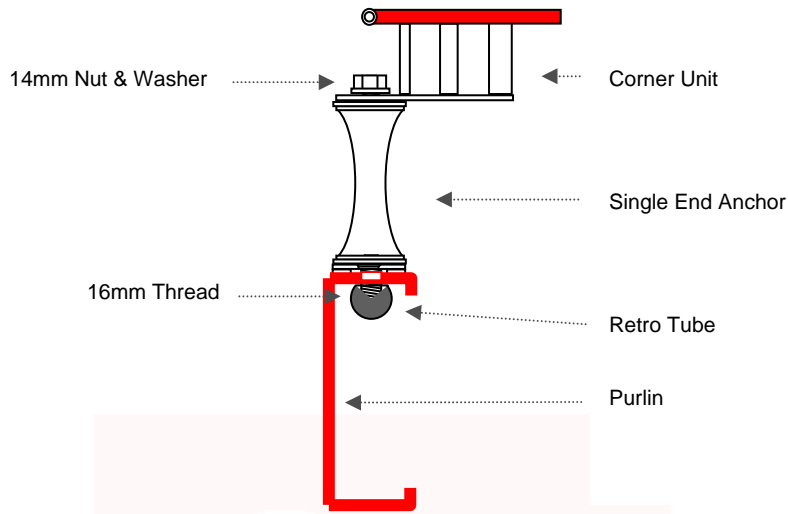

COMPONENTS:

14 mm Nuts

14 mm Spring Washers

Corner Unit

Single End Anchor Absorbing Bolt

Rubber O Ring

Retro washer with rubber

Plastic Washer

Tightening Cables & Retro Tube

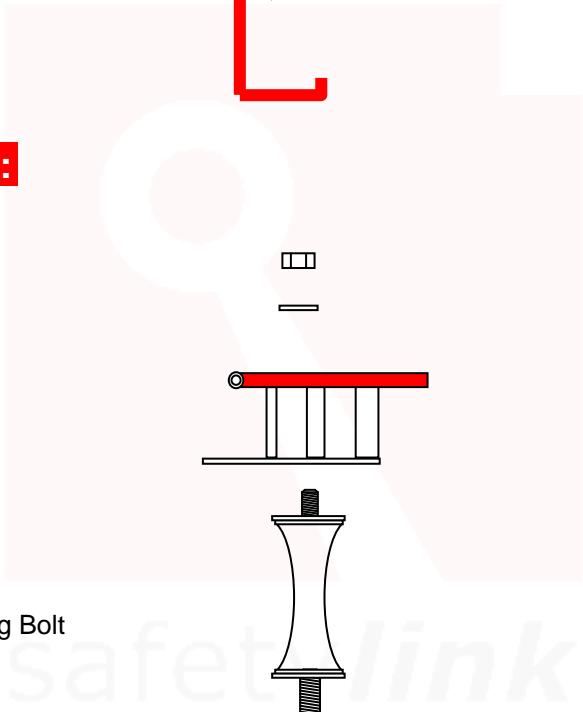



INSTALLATION: ROOF SHEET BELOW 25 DEGREES

⚠ During installation you must be safe at all times.

After locating Purlin

1. Locate the centre of the purlin and drill a 25mm hole.

After drilling 25mm hole in purlin

2. Hold onto the positioning ties and slide the Retro Tube vertically through the 25mm hole. Once the tube is through the hole, reorientate it to a horizontal position.

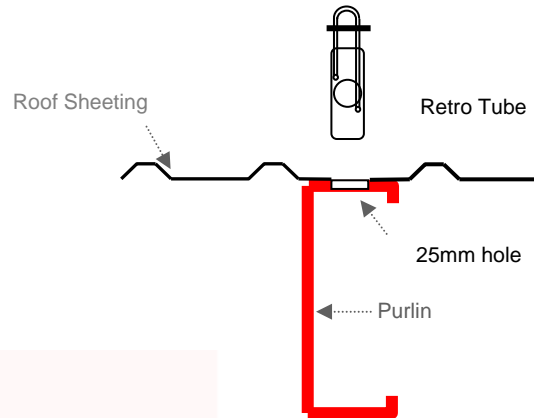

3. Slide the plastic washer down the positioning ties and draw the Retro Tube up to the underside of the purlin.

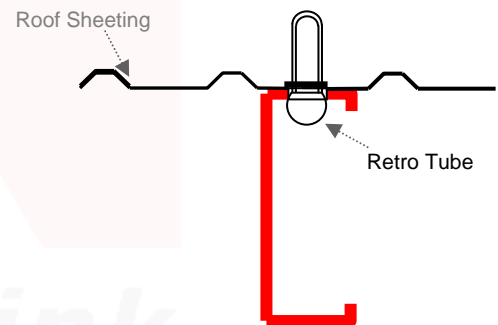

4. Coat around the plastic washer with silicone, then place the retro washer with rubber in a central location over the plastic washer.

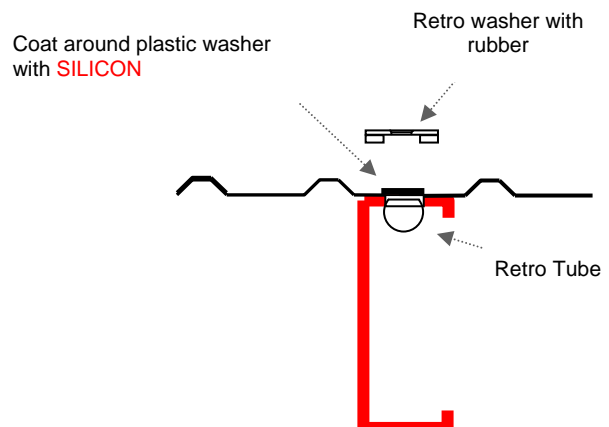



INSTALLATION: Continued ...

Note: Threads need to have a minimum of **six full 360° turns** into the ultimate thread.

5. Apply silicone around the centre of the washer, to seal between Single End Anchor and Retro washer with rubber.

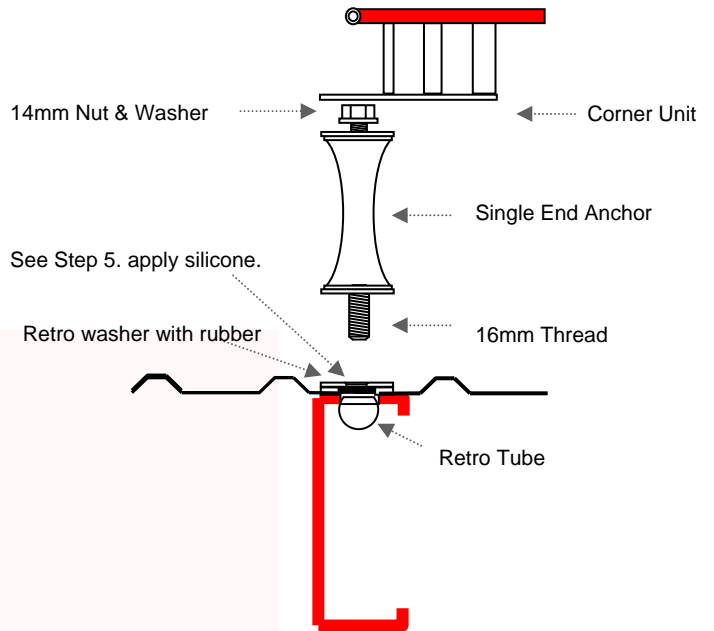

6. Screw the Single End Anchor into the Retro Tube. Install the Corner Unit and tighten the 14mm nut and spring washer whilst tightening the Single End Anchor into the tube making certain the Corner Unit lines up with the run of the StaticLine.

Use Loctite on all threads.

(IMPORTANT NOTE: Before applying Loctite 243 use Loctite 7471 primer to activate the surface according to manufacturer's instructions).

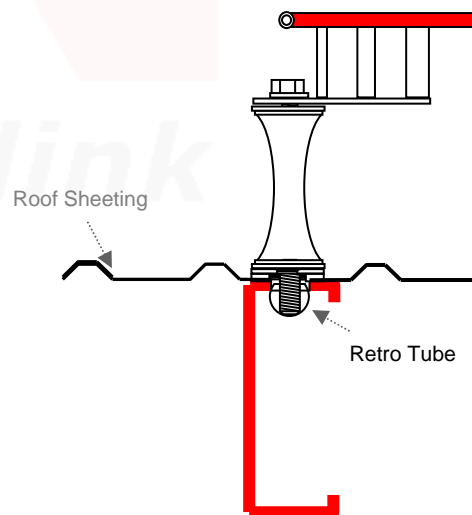

Inspect the steel for strength.

⚠ If any doubt exists as to the strength of the structure an engineer should make the assessment.

⚠ During installation you must be safe at all times.

INSTALLATION: ROOF SHEET BELOW 25 DEGREES

1. Swage cable to Swaged/Swageless Termination (Termination).
2. Connect Termination to S Cable End Support at opposite end to Tensioner.
3. Run cable through Intermediate T Bolts to opposite end of StaticLine (Intermediate T Bolts must be installed as per installation manual, **maximum distance between Intermediate T Bolts 10 metres**).
4. Connect Tension Indicator to S Cable End Support.
5. Connect a Swaged/Swageless Tensioner (Tensioner) to Tension Indicator.
6. Open out Tensioner.
7. Match up cable so it reaches into Tensioner and mark cable.
8. Cut cable to length.
9. Swage cable to Tensioner.
10. Tension cable till disc on Tension Indicator can be spin freely.

Complete layout diagram on following page.

Tightening Torque for Swageless Terminals:

Wire size:		Nm	Lbf ft
Ø 3	-	11	8.25
-	1/8"	11	8.25
Ø 4	5/32"	17	12.75
-	3/16"	22	16.5
Ø 5	-	22	16.5
-	7/32"	38	28.5
Ø 6	-	38	28.5
-	1/4"	38	28.5
Ø 7	9/32"	48	35.5
Ø 8	5/16"	58	43.0
-	3/8"	75	55.5
Ø 10	-	75	55.5
Ø 12	-		
-	1/2"		
Ø 14	-		
Ø 16	-		



RETROLINK TUBE – SETTING OUT

SETTING OUT: ROOF SHEET BELOW 25 DEGREES

WARNING: RetroLink Anchors should be positioned 2 metres from the edge on Cliplock roofs.

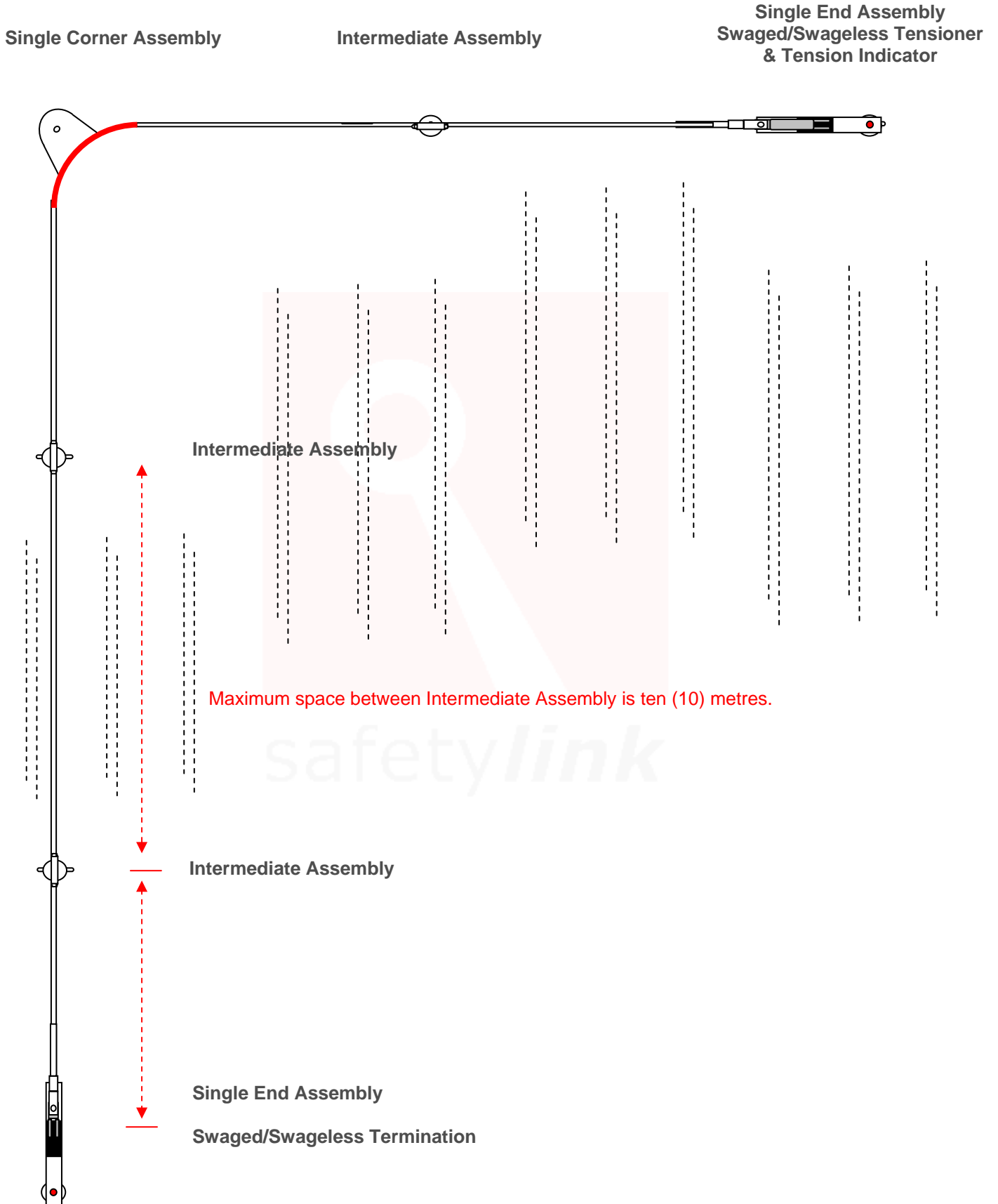



IN CASE OF ACCIDENT

⚠ A FALL RESCUE PLAN SHOULD BE DEVELOPED PRIOR TO USING SAFETYLINK EQUIPMENT.

⚠ Persons working at heights should not work alone.

It is critical that before using any SafetyLink Systems a fall rescue plan is in place for any persons suspended mid-air following a fall. Serious injury or death can occur in a matter of minutes, particularly if a person's movement or breathing is restricted or loss of consciousness has occurred. In accordance with your fall rescue plan and appropriate first aid procedures it is essential to remove the person from the suspended position as quickly as possible.

EQUIPMENT WHICH HAS ARRESTED A FALL OR SHOWS A DEFECT

In accordance with AS/NZS 1891.4:2000 clause 9.5

Any piece of equipment which has been involved in an accident must be withdrawn from service immediately and a replacement obtained if necessary. A label indicating the condition or defect should be attached to the equipment, and it should be examined by a competent person who will decide whether the equipment is to be destroyed or repaired if necessary and returned to service. In the latter case, details of any repair shall be documented and a copy given to the operator.



DISTRIBUTOR:

www.heightsafety.com