



safetylink™

INSTALLATION HANDBOOK:
HORIZONTAL STATICLINE
Advance SurfaceLink (SINGLE END)
Installation to Roof Sheet Surface



READ ENTIRE HANDBOOK BEFORE INSTALLING ANY SAFETYLINK PRODUCT.

ALL PRODUCTS MUST BE INSTALLED IN ACCORDANCE WITH SAFETYLINK'S
INSTALLATION HANDBOOK, USING ONLY PRODUCTS SUPPLIED BY SAFETYLINK PTY LTD.

**FAILURE TO FOLLOW ALL WARNINGS AND INSTRUCTIONS MAY
RESULT IN A SERIOUS INJURY OR DEATH.**

If you are uncertain and need help please email: safetylink@heightsafety.com.au
Phone: +61 249 972272 | Freecall: 1800 972272 | Fax: +61 249 971104
or visit our website www.heightsafety.com



INSTALLATION OF A SAFETYLINK STATICLINE SYSTEM USING ADVANCE SURFACELINKS ON ROOF SHEET SURFACE

	PAGE
WARNINGS: INSTALLATION AND USE	3
MAINTENANCE: PERIODIC INSPECTIONS	4
WARRANTIES:	5
BELOW 25 DEGREES – SINGLE END ASSEMBLY	
SETTING OUT.....	6
COMPONENTS	7
ASSEMBLING	8
INSTALLATION	9
BELOW 25 DEGREES – INTERMEDIATE ASSEMBLY	
COMPONENTS	10
ASSEMBLING	11
INSTALLATION	12
SETTING OUT	13
BELOW 25 DEGREES – SINGLE CORNER ASSEMBLY	
COMPONENTS.....	14
ASSEMBLING	15
ASSEMBLING CORNER TUBE	16
SETTING OUT.....	17
INSTALLATION	18
STATICLINE SYSTEM INSTALLATION	19
TIGHTENING TORQUE FOR SWAGELESS TERMINALS	19
EXAMPLE OF STATICLINE LAYOUT	20
NOTES	21
IN CASE OF AN ACCIDENT:	22





WARNINGS

READ CAREFULLY SOMEONE'S LIFE DEPENDS ON IT

- The building or structure for the anchorages should be assessed by an engineer, unless it is clear to a competent person that the structure is adequate.
- All safety procedures must be complied with in accordance with the current safety code(s) of practice(s) for working at heights. Ensure safety at all times by being attached to anchor point approved safety equipment, using a scaffold or a secured ladder.
- Installation is to be carried out by, or under the supervision of a competent person.
- To prevent galling use a spray can of nickel anti-seize.
- Recommended waterproofing for roof tiles: *Sika Flex Co-Polymer Sealant*.
- Recommended waterproofing for metal roof: *Silicone Sealant*.
- All threads must be coated with Loctite prior to assembly. (IMPORTANT NOTE: Before applying Loctite 243 use Loctite 7471 primer to activate the surface according to manufacturer's instructions).
- SafetyLink StaticLine's must be installed to roofs below 25 degrees.

WARNING: Surface Mounted Anchors should be positioned 2 metres from the edge on Cliplock roofs.

-  **Maximum user per system is Four (4).**
-  **Maximum person per span is Two (2).**
-  **See system information for site specific use.**

WARNING

Locking Hex Nut must be fully screwed up the thread of the eyebolt to expose 30mm of thread.
This thread must be fully screwed into the bracket.

(Loctite must be used on all threads)

Locking Hex Nut must be firmly tightened onto the bracket to stop the Intermediate T Bolt from unscrewing and to gain maximum strength.

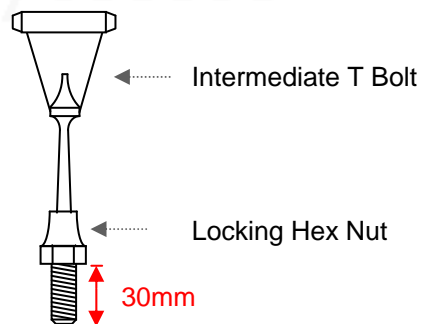



MAINTENANCE – PERIODIC INSPECTIONS

All items of equipment which are in regular use shall be subjected to periodic inspection and servicing.

These regular scheduled inspections and servicing must be carried out by a competent person (*refer to AS/NZS 1891.4:2000 section 9 if clarification required or contact SafetyLink*).

SafetyLink Anchorages (*In accordance with AS/NZS 1891.4:2000 clause 9.3.3 and 9.3.5*)

ALL ANCHORAGES MUST BE INSPECTED EVERY 12 MONTHS.

Procedures to be followed at inspection time:

- Visually inspect anchors for signs of deterioration.
- The End Anchor Tapered Bolt and Intermediate T Bolts should remain straight, a bent End Anchor Tapered Bolt or Intermediate T Bolt will indicate that the StaticLine has arrested a fall (*The design features of the End Anchor Tapered Bolt and Intermediate T Bolts includes the ability to bend like a fishing pole starting from the top and working its way to the bottom, enabling it to use up energy as the Anchor bends whilst lessening the force on the person falling and the attachment point*).
- Visually inspect the components of the anchor for corrosion, superficial surface marking is permitted while deeper corrosion or pitting would require attention.
- Manually (by hand) check the End Anchor Tapered Bolt and Intermediate T Bolt for rigidity and tightness, if the End Anchor Tapered Bolt and Intermediate T Bolt can turn in the anticlockwise direction it will require attention.
- Visually inspect the attachment component of the anchorage where practically possible.
- Visually inspect the parent structure for modifications or deterioration which might lead to loss of anchorage strength.
- Check the condition of line Tensioners and Energy Absorbers.
- Check for any evidence of wear, cuts, looseness, extension, interstrand wear, corrosion, stiffness, brittleness or fraying of the steel cable.
- Check the integrity of cable terminations.
- Check for the presence of contaminants or exposure to a corrosive or extreme environment which could significantly reduce the working load of the StaticLine.
- Run the SafeLink Shuttle along the length of the line to verify its correct function.

IN ADDITION TO SAFETYLINK PTY LTD EQUIPMENT, ALL ANCILLARY EQUIPMENT MUST BE INSPECTED IN ACCORDANCE WITH APPLICABLE REGULATORY REQUIREMENTS AND THE MANUFACTURER'S INSTRUCTIONS.



FOR MAINTENANCE ADVICE AND SERVICES PLEASE CONTACT SAFETYLINK ON 0249 972272 OR 1800 972272 FOR YOUR NEAREST SAFETYLINK INSPECTION SERVICE CENTRE OR EMAIL: safetylink@heightsafety.com.au

To download Installation Manuals on other SafetyLink products please visit our website at www.heightsafety.com



WARRANTIES

EXTRACT: SafetyLink Pty Ltd STANDARD TERMS AND CONDITIONS

- 11.1 To the extent permitted by law all implied conditions, warranties and undertakings are expressly excluded.
- 11.2 Except as provided in this clause the Company shall not be liable for any loss or damage, whether direct or indirect (including consequential losses or damage) arising out of any breach of contract by the Company or any negligence of the Company, its employees or agents.
- 11.3 Should the Company be liable for a breach of a guarantee, condition or warranty implied by the Australian Consumer Law (not being a guarantee, condition or warranty implied by sections 51, 52 and 53 of that Law) then its liability for a breach of any such condition or warranty express or implied shall be limited, at its option, to any one or more of the following.
- A) in case of Goods
- (I) the replacement of the Goods or the supply of equivalent Goods.
 - (II) the repair of the goods,
 - (III) the payment of the cost of replacing the Goods or acquiring equivalent Goods.
 - (IV) The payment of the cost of having the Goods repaired.
- Provided that any such Goods are returned to the Company by the Purchaser at the Purchaser's expense.
- B) in the case of services
- (i) the supply of the services again,
 - (ii) the payment of the cost of having the services supplied again.
- 11.4 The Company will not be liable for the costs of recovery of the Goods from the field, loss of use of the Goods, loss of time, inconvenience, incidental or consequential loss or damage, nor for any other loss or damage of her than as stated above, whether ordinary or exemplary, caused either directly or indirectly by use of the Goods.
- 11.5 The Company warrants that at the time of shipment, Products manufactured by it will be free from defects in material and workmanship. In the absence of a modified written warranty, the Company agrees to making good any such defects by repairing the same or at the Company's option by replacement, for a period of (1) one year from the date of shipment. This limited warranty applies provided that:
- (a) defects have arising solely from faulty materials or workmanship;
 - (b) the Products have not received maltreatment, inattention or interference;
 - (c) **the Products have been installed in accordance with the Company's Installation Handbooks using only products supplied by the Company;**
 - (d) accessories used with the Products are manufactured by or approved by the Company ;
 - (e) the Products are maintained in accordance with Australian Standard 1891.4 (section 9).
 - (f) you notify any claim under this warranty to SafetyLink in writing to the address below no later than 14 days after the event or occurrence concerning the produce giving rise to the claim and you pay all costs related to your claim.
- This warranty does not apply to any defects or other malfunctions caused to the Goods by accident, neglect, vandalism, misuse, alteration, modification or unusual physical, environment or electrical stress.
- Please note that the benefits to the purchaser (as a consumer) given by this warranty are in addition to your other rights and remedies under the Australian Consumer Law. Our goods come with guarantees that cannot be excluded under the Australian Consumer Law. You are entitled to a replacement or refund for a major failure and compensation for any other reasonably foreseeable loss or damage. You are also entitled to have the goods repaired or replaced if the goods fail to be of acceptable quality and the failure does not amount to a major failure.
- 11.6 If any goods are not manufactured by the Company, the guarantee of the manufacturer thereof shall be accepted by the Purchaser as the only express warranty given in respect of the goods.
- 11.7 Except as provided in this clause 11, all express and implied warranties, guarantees and conditions under statute or general law as the merchantability, description, quality, suitability or fitness of the Products for any purpose or as to design, assembly, installation, materials or workmanship or otherwise are hereby expressly excluded (to the extent to which they may be excluded by law).

PLEASE SEE SAFETYLINK PTY LTD FULL STANDARD TERMS OF CONDITIONS OF SALE FOR FURTHER REFERENCE.



SETTING OUT: ROOF SHEET BELOW 25 DEGREES

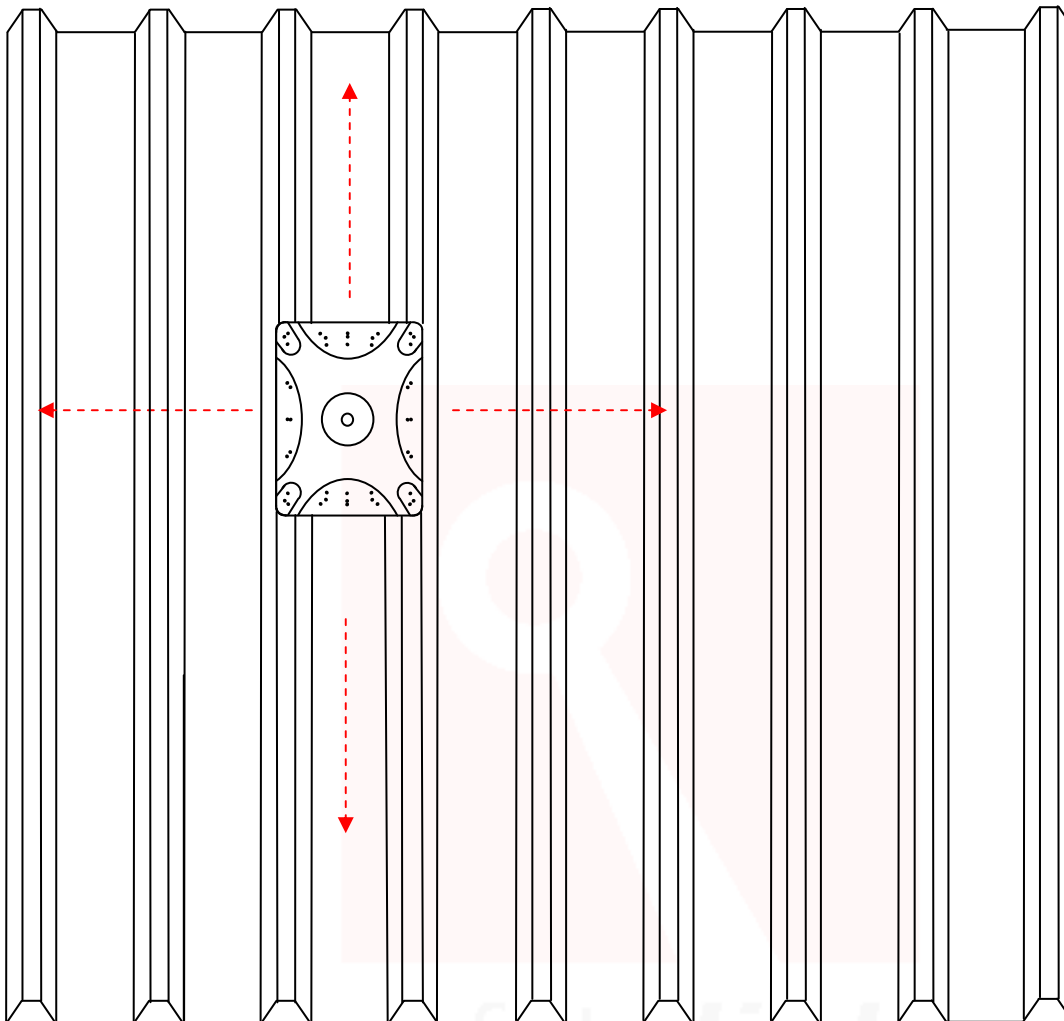

Multidirectional

Inspect the steel for strength

Inspect how well the metal roof sheeting is secured to the structure. Minimum sheet gauge 0.42mm.

⚠ If any doubt exists as to the strength of the structure an engineer should make the assessment.

WARNING: Surface Mounted Anchors should be positioned 2 metres from the edge on Cliplock roofs.

1. Place Surface Mounted End Anchor in desired location to match holes with roof profile.
2. Mark out position of Surface Plate on roof profile so it can be removed to install End Anchor.



INSTALLATION OF A SAFETYLINK STATICLINE SYSTEM USING SURFACELINKS ON ROOF SHEET SURFACE BELOW 25 DEGREES

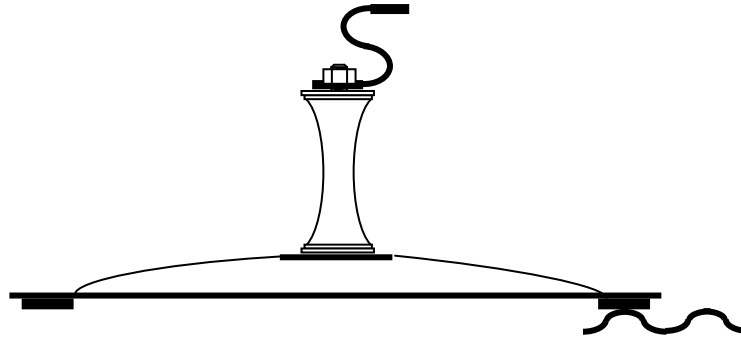

COMPONENTS:

14 mm Nuts



14 mm Spring Washers



S Cable End Support



Single End Anchor Absorbing Bolt



70mm Rubber Washer



Advance Surface Plate

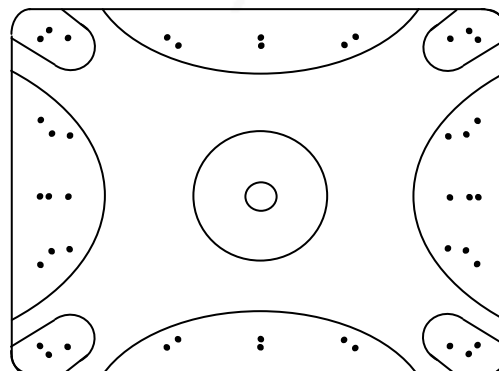

50mm Rubber Washer



50mm Washer



16mm Nut





ADVANCE SURFACELINK – SINGLE END ASSEMBLY

Product Code: STAT.ASURF002

ASSEMBLING:

STEP 1

Apply adhesive waterproofing membrane under rivet location.

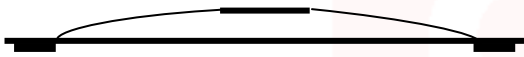
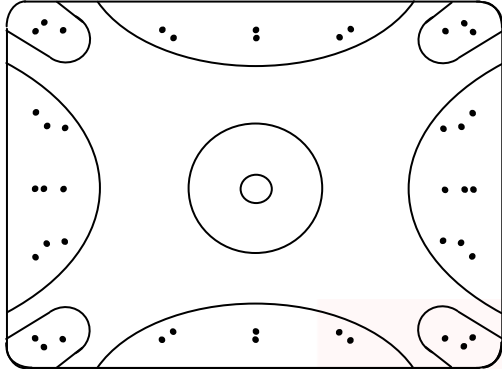

STEP 2

Insert the Single End Anchor through 70mm Rubber Washer and Surface Plate.

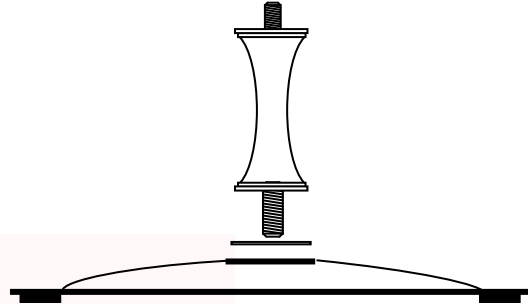

STEP 3

Apply a 50mm rubber washer, 50mm washer and 16mm nut to the underside of the Advance SurfaceLink Plate. Tighten the nut finger tight.

Note: Use Locktite on all threads.

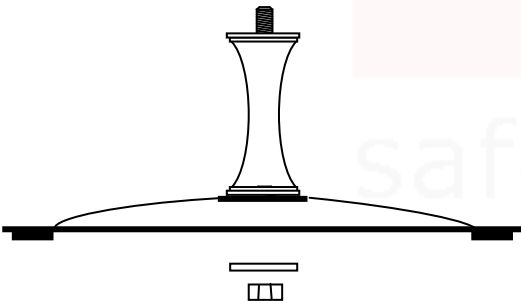

STEP 4

Tighten the 16mm nut.

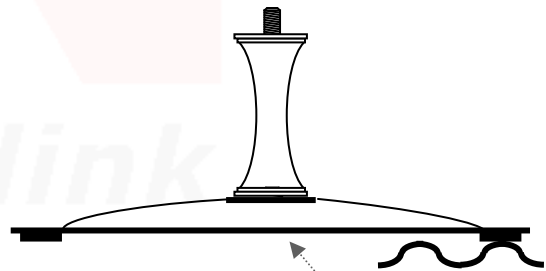

50mm Rubber Washer
50mm Washer & 16mm Nut

STEP 5

Install the S Cable End Support and tighten the 14mm nut and spring washer making certain the S Cable End Support lines up with run of the StaticLine. **Note: Use Locktite on all threads.**

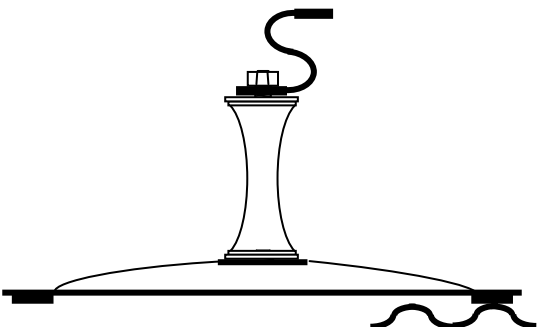

Note: Threads need to have a minimum of six full 360° turns into the ultimate thread.



INSTALLATION: ROOF SHEET BELOW 25 DEGREES

1. Place SurfaceLink on surface of roof sheets in required location.
2. Drill Ten (10) 8mm holes into roof sheets through locating holes on both sides of the SurfaceLink (5 each side).
3. Secure the SurfaceLink to the roof by riveting through holes in surface mounted end anchor and roof sheet using 8mm Gesipa rivets.

⚠ During installation you must be safe at all times.

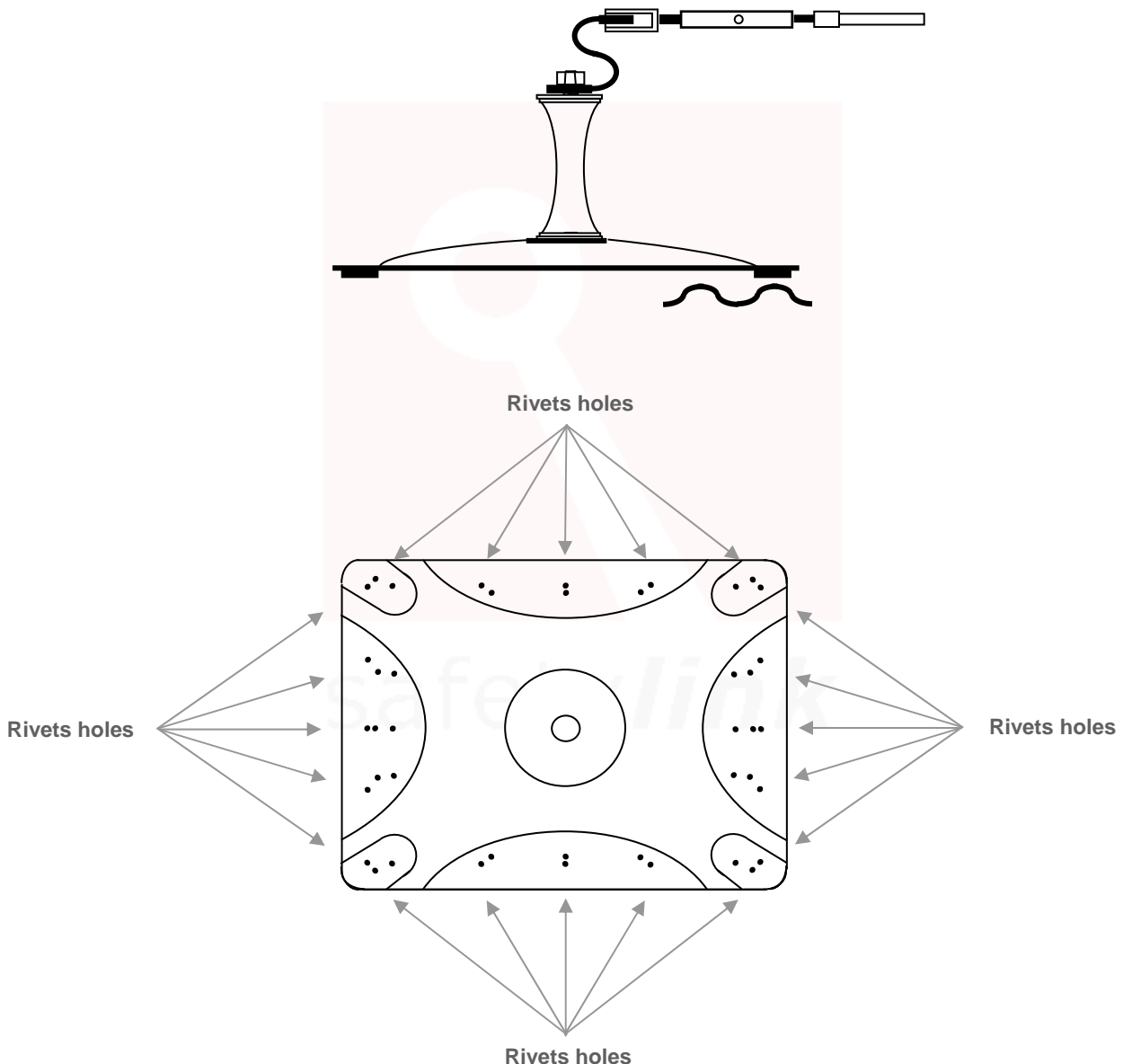

Inspect the steel for strength.

Inspect how well the metal roof sheeting is secured to the structure. Minimum sheet gauge 0.42mm.

Intermediate T Bolts must be spaced at maximum 10 metres apart.

⚠ If any doubt exists as to the strength of the structure an engineer should make the assessment.

⚠ During installation you must be safe at all times.



INSTALLATION OF A SAFETYLINK STATICLINE SYSTEM USING ADVANCE SURFACELINKS ON ROOF SHEET SURFACE BELOW 25 DEGREES

Intermediate T Bolt

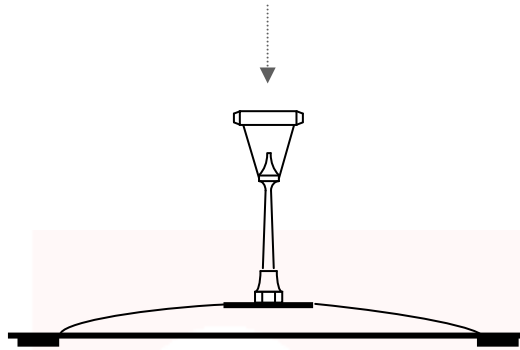

COMPONENTS:



Intermediate T Bolt

Advance Surface Plate

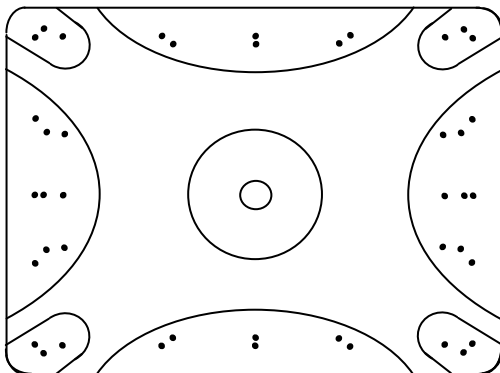

Locking Hex Nut



50mm Rubber Washer



50mm Washer



16mm Nut



INSTALLATION: TO THE SURFACE OF A ROOF

ASSEMBLING:

Maximum distance between Intermediate T Bolts is ten (10) metres.

Note: Threads need to have a minimum of **six full 360° turns** into the ultimate thread.

(IMPORTANT NOTE: Before applying Loctite 243 use Loctite 7471 primer to activate the surface according to manufacturer's instructions).

STEP 1

Apply adhesive waterproofing membrane under rivet location.

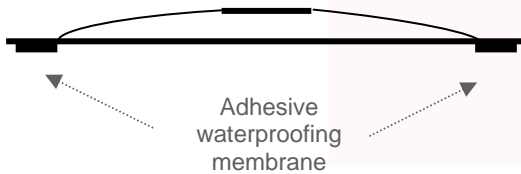
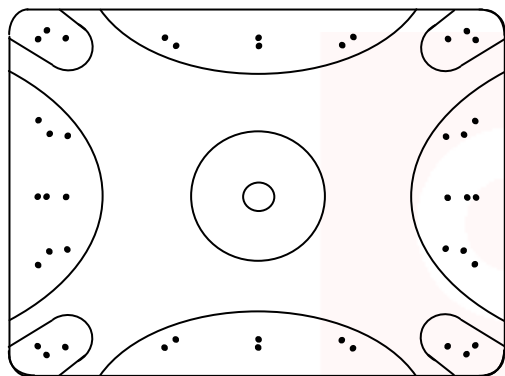

STEP 2

Screw locking hex nut into Intermediate T Bolt leaving 30mm of thread (coat threads with Loctite).

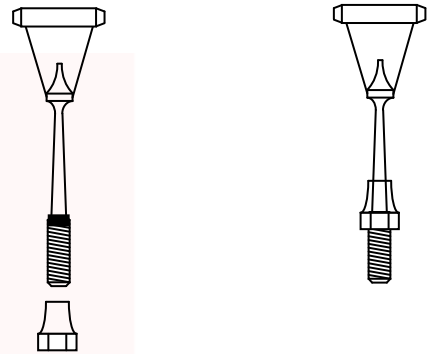

STEP 3

Insert Intermediate T Bolt through Advance SurfaceLink Plate.

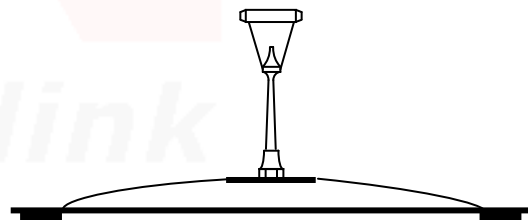

STEP 4

Apply 50mm rubber washer, 50mm washer and 16mm nut, tighten nut finger tight (coat threads with Loctite).

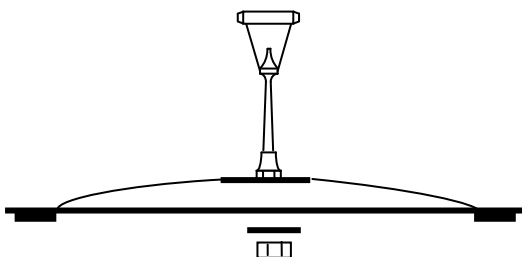

STEP 5

Tighten nut and Locking Hex Nut making certain the Intermediate T-Bolt lines up with the run of the line.

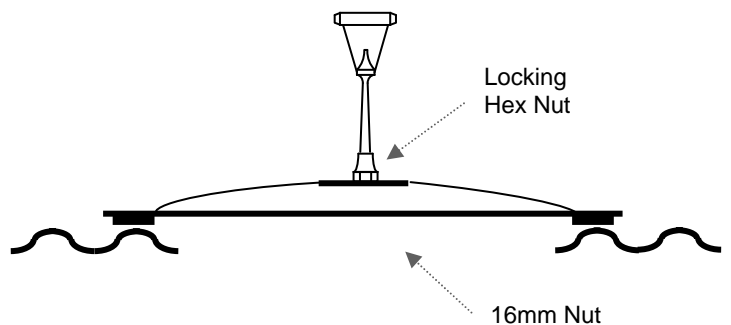



INSTALLING: STEPS: 1 to 3

WARNING: Surface Mounted Anchors should be positioned 2 metres from the edge on Cliplock roofs.

- 1) Place SurfaceLink on surface of roof sheets in required location.
- 2) Drill Ten (10) 8mm holes into roof sheets through locating holes on both sides of the SurfaceLink (5 each side).
- 3) Secure the SurfaceLink to the roof by riveting through holes in surface mounted end anchor and roof sheet using 8mm Gesipa rivets.

⚠ During installation you must be safe at all times.

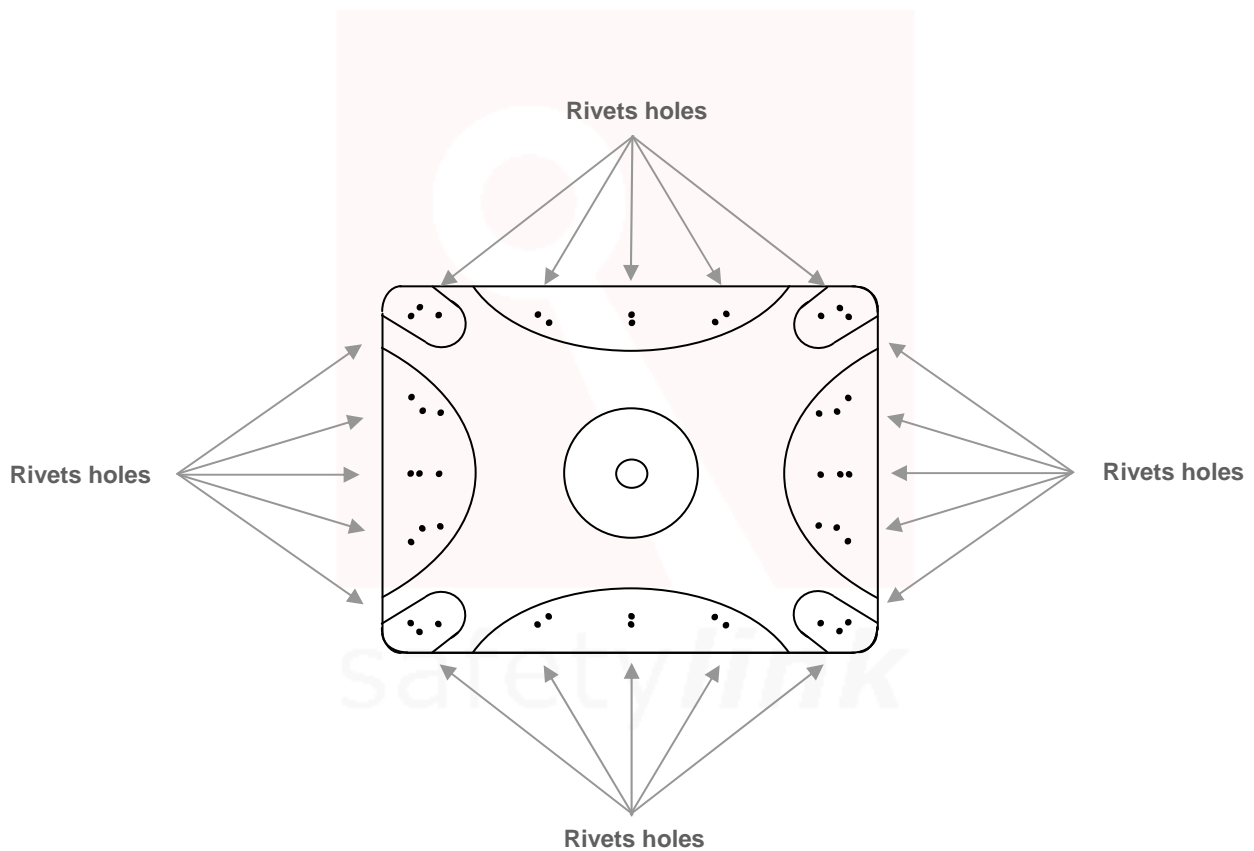

Inspect the steel for strength.

Inspect how well the metal roof sheeting is secured to the structure. Minimum sheet gauge 0.42mm.

Intermediate T Bolts must be spaced at maximum 10 metres apart.

⚠ If any doubt exists as to the strength of the structure an engineer should make the assessment.

⚠ During installation you must be safe at all times.



SETTING OUT: ROOF SHEET BELOW 25 DEGREES

WARNING: Surface Mounted Anchors should be positioned 2 metres from the edge on Cliplock roofs.

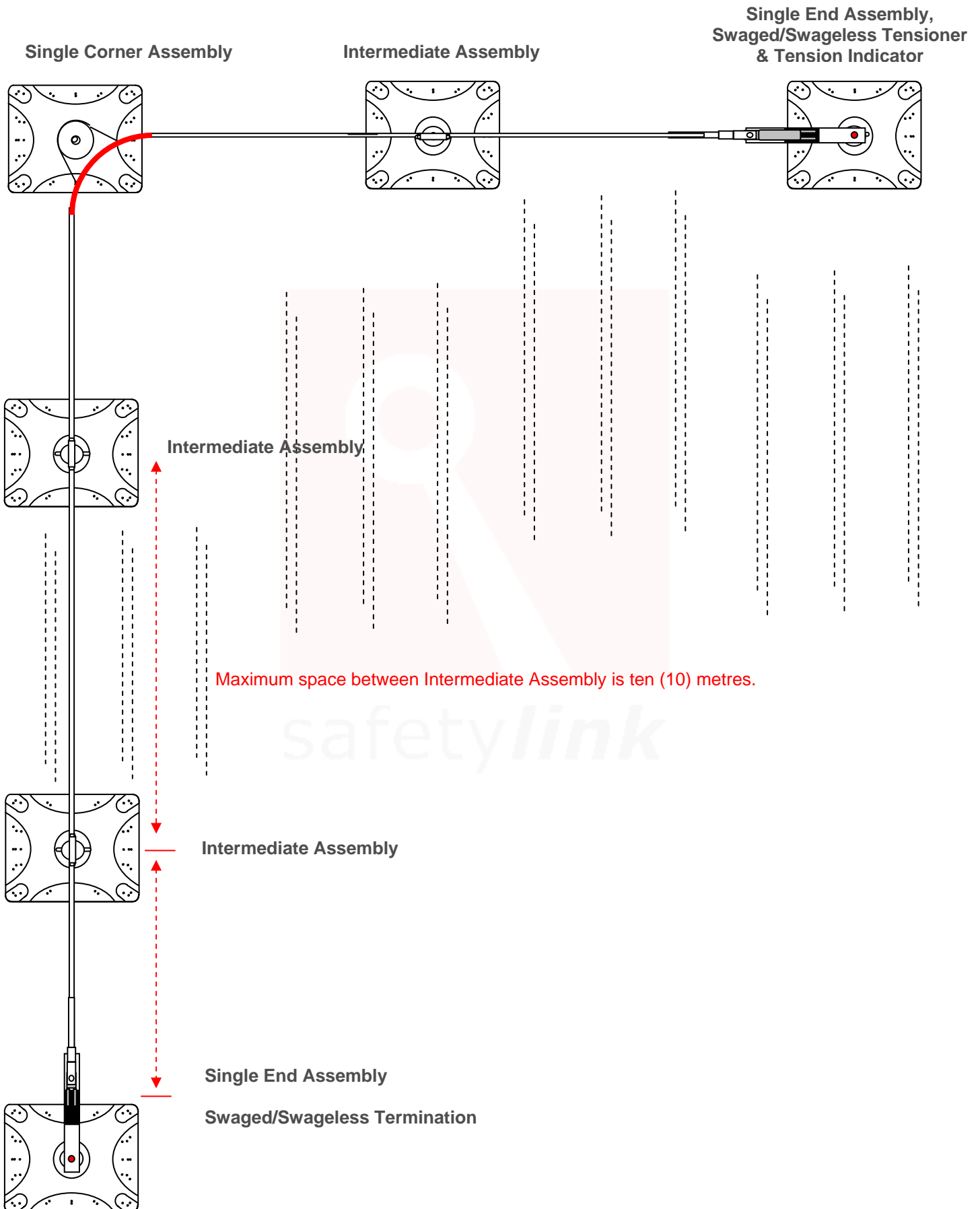



INSTALLATION OF A SAFETYLINK STATICLINE SYSTEM USING ADVANCE SURFACELINKS ON ROOF SHEET SURFACE BELOW 25 DEGREES

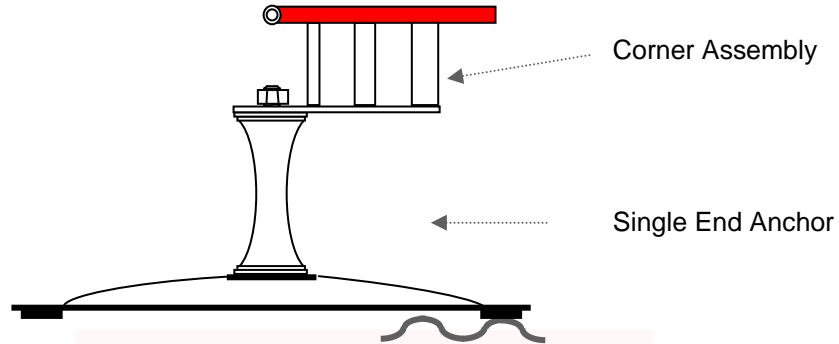

COMPONENTS:

Corner Unit

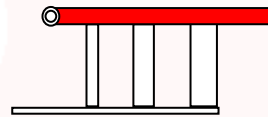

14 mm Nuts



14 mm Spring Washers



Single End Anchor Absorbing Bolt



70mm Rubber Washer



Advance Surface Plate

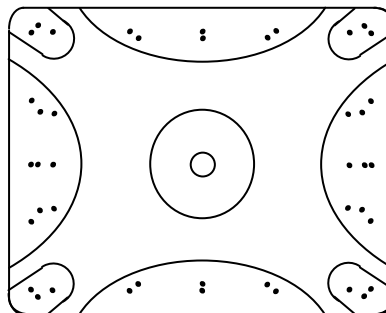

50mm Rubber Washer



50mm Washer



16mm Nut





ASSEMBLING:

Note: Threads need to have a minimum of **six full 360° turns** into the ultimate thread.

STEP 1

Apply adhesive waterproofing membrane under rivet location.

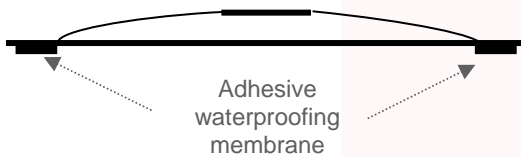
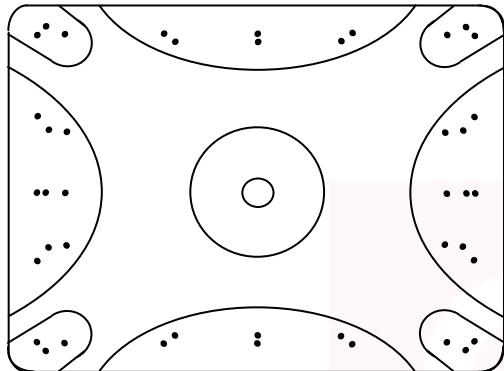

STEP 2

Insert the Single End Anchor through 70mm Rubber Washer and Advance SurfaceLink Plate.

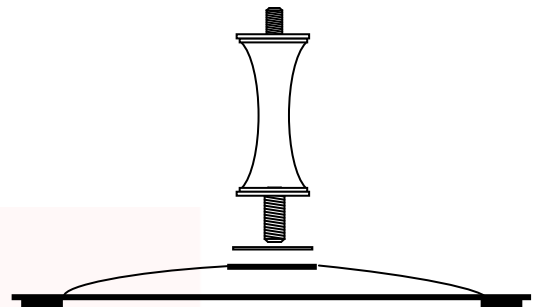

STEP 3

Apply a 50mm rubber washer, 50mm washer and 16mm nut to the underside of the Advance SurfaceLink Plate. Tighten the nut finger tight.

Note: Use Loctite on all threads.

STEP 4

Tighten the 16mm nut.

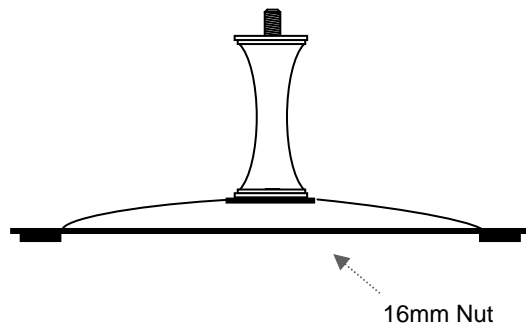
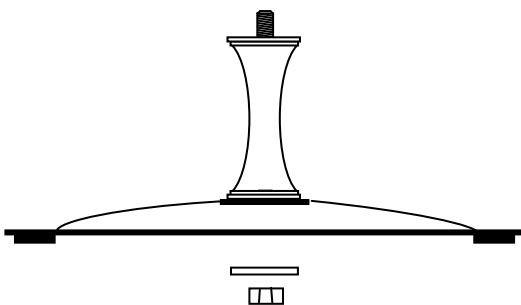

(IMPORTANT NOTE: Before applying Loctite 243 use Loctite 7471 primer to activate the surface according to manufacturer's instructions).



ASSEMBLING THE CORNER TUBE:

STEP 1

Secure Corner Unit into place using a 14mm washer and 14mm nut.

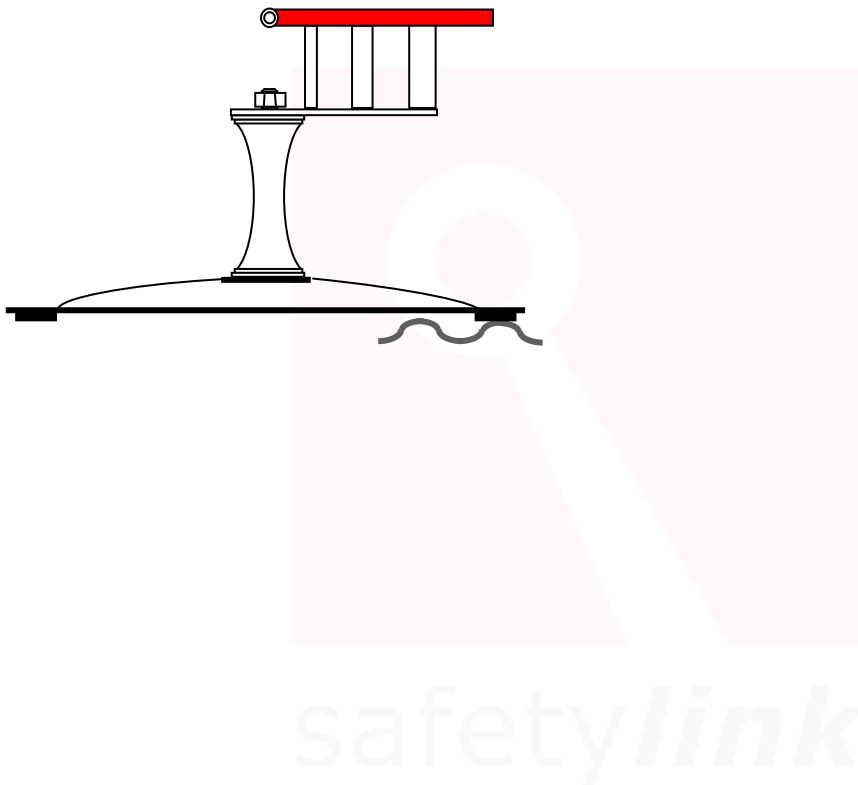



SETTING OUT: ROOF SHEET BELOW 25 DEGREES

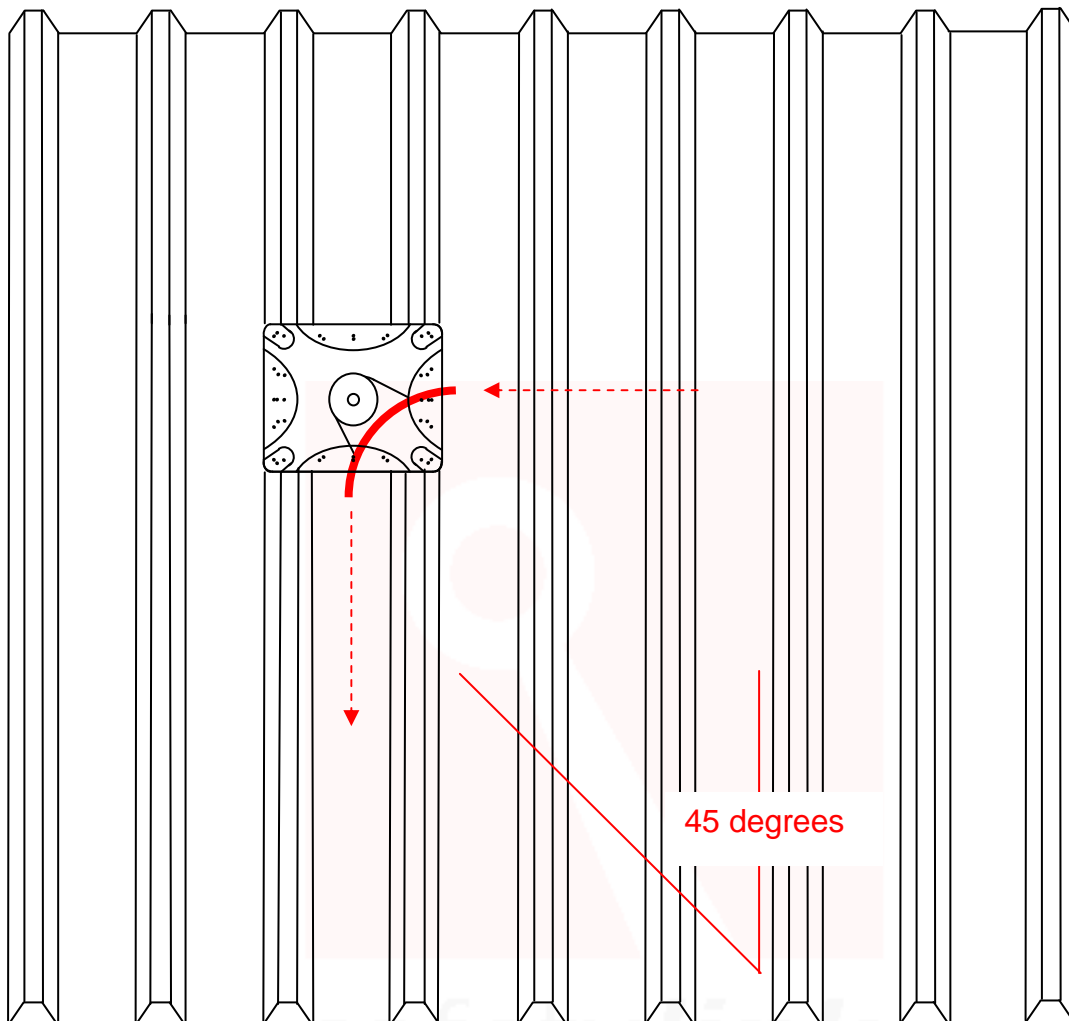

Multidirectional: Single corner assembly can be rotated to line up in any direction.

1. Place Surface Mounted End Anchor in desired location to match holes with roof profile.
2. Line up corner tube with run of staticline.
3. Mark position of plate on roof profile ready for installation.

WARNING: Surface Mounted Anchors should be positioned 2 metres from the edge on Cliplock roofs.



INSTALLATION: ROOF SHEET BELOW 25 DEGREES

WARNING: Surface Mounted Anchors should be positioned 2 metres from the edge on Cliplock roofs.

1. Place SurfaceLink on surface of roof sheets in required location.
2. Drill Ten (10) 8mm holes into roof sheets through locating holes on both sides of the SurfaceLink (5 each side).
3. Secure the SurfaceLink to the roof by riveting through holes in surface mounted end anchor and roof sheet using 8mm Gesipa rivets.

⚠ During installation you must be safe at all times.

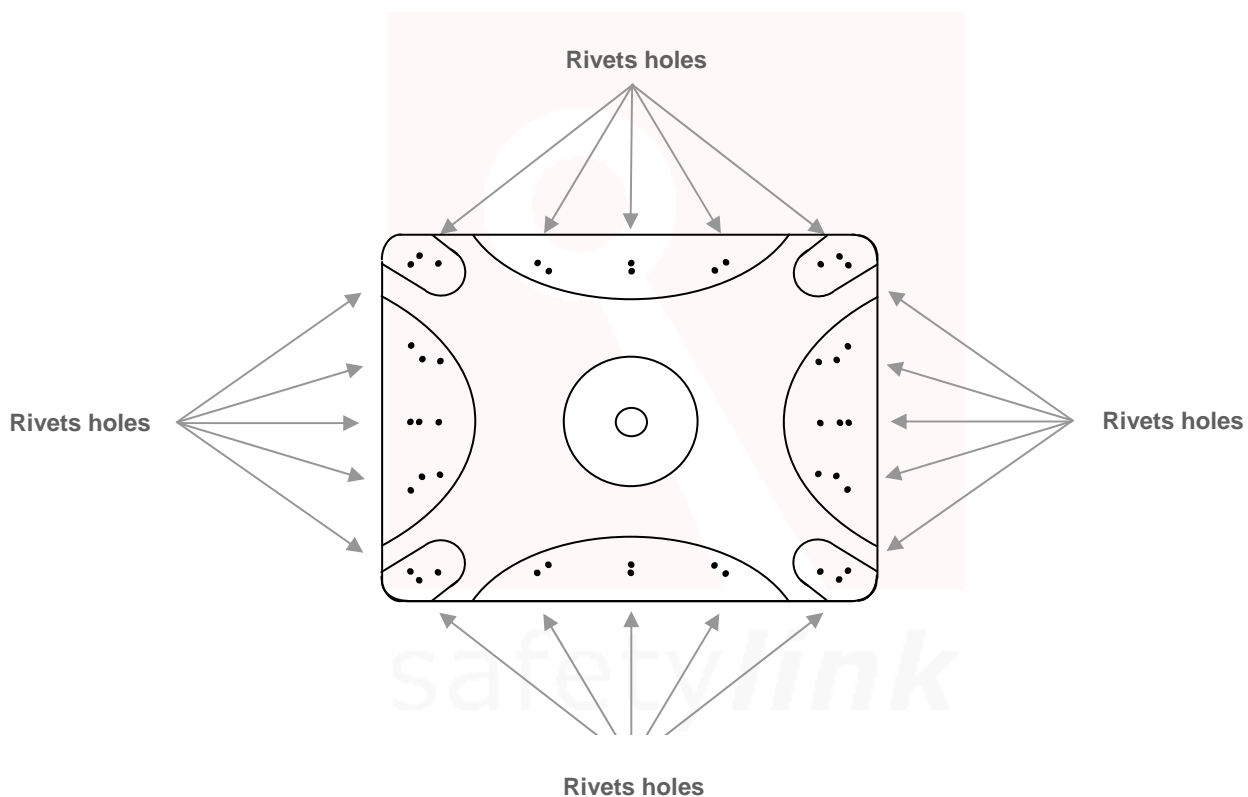

Inspect the steel for strength.

Inspect how well the metal roof sheeting is secured to the structure. Minimum sheet gauge 0.42mm.

Intermediate T Bolts must be spaced at maximum 10 metres apart.

⚠ If any doubt exists as to the strength of the structure an engineer should make the assessment.

⚠ During installation you must be safe at all times.



INSTALLATION: ROOF SHEET BELOW 25 DEGREES

1. Swage cable to Swaged/Swageless Termination (Termination).
2. Connect Termination to S Cable End Support at opposite end to Tensioner.
3. Run cable through Intermediate T Bolts to opposite end of StaticLine (Intermediate T Bolts must be installed as per installation manual, **maximum distance between Intermediate T Bolts 10 metres**).
4. Connect Tension Indicator to S Cable End Support.
5. Connect a Swaged/Swageless Tensioner (Tensioner) to Tension Indicator.
6. Open out Tensioner.
7. Match up cable so it reaches into Tensioner and mark cable.
8. Cut cable to length.
9. Swage cable to Tensioner.
10. Tension cable till disc on Tension Indicator can be spin freely.

Complete layout diagram on following page.

Tightening Torque for Swageless Terminals:

Wire size:		Nm	Lbf ft
Ø 3	-	11	8.25
-	1/8"	11	8.25
Ø 4	5/32"	17	12.75
-	3/16"	22	16.5
Ø 5	-	22	16.5
-	7/32	38	28.5
Ø 6	-	38	28.5
-	1/4"	38	28.5
Ø 7	9/32"	48	35.5
Ø 8	5/16"	58	43.0
-	3/8"	75	55.5
Ø 10	-	75	55.5
Ø 12	-		
-	1/2"		
Ø 14	-		
Ø 16	-		



ADVANCE SURFACELINK – SINGLE CORNER ASSEMBLY

Product Code: STAT.ASURF003

SETTING OUT: ROOF SHEET BELOW 25 DEGREES

WARNING: Surface Mounted Anchors should be positioned 2 metres from the edge on Cliplock roofs.

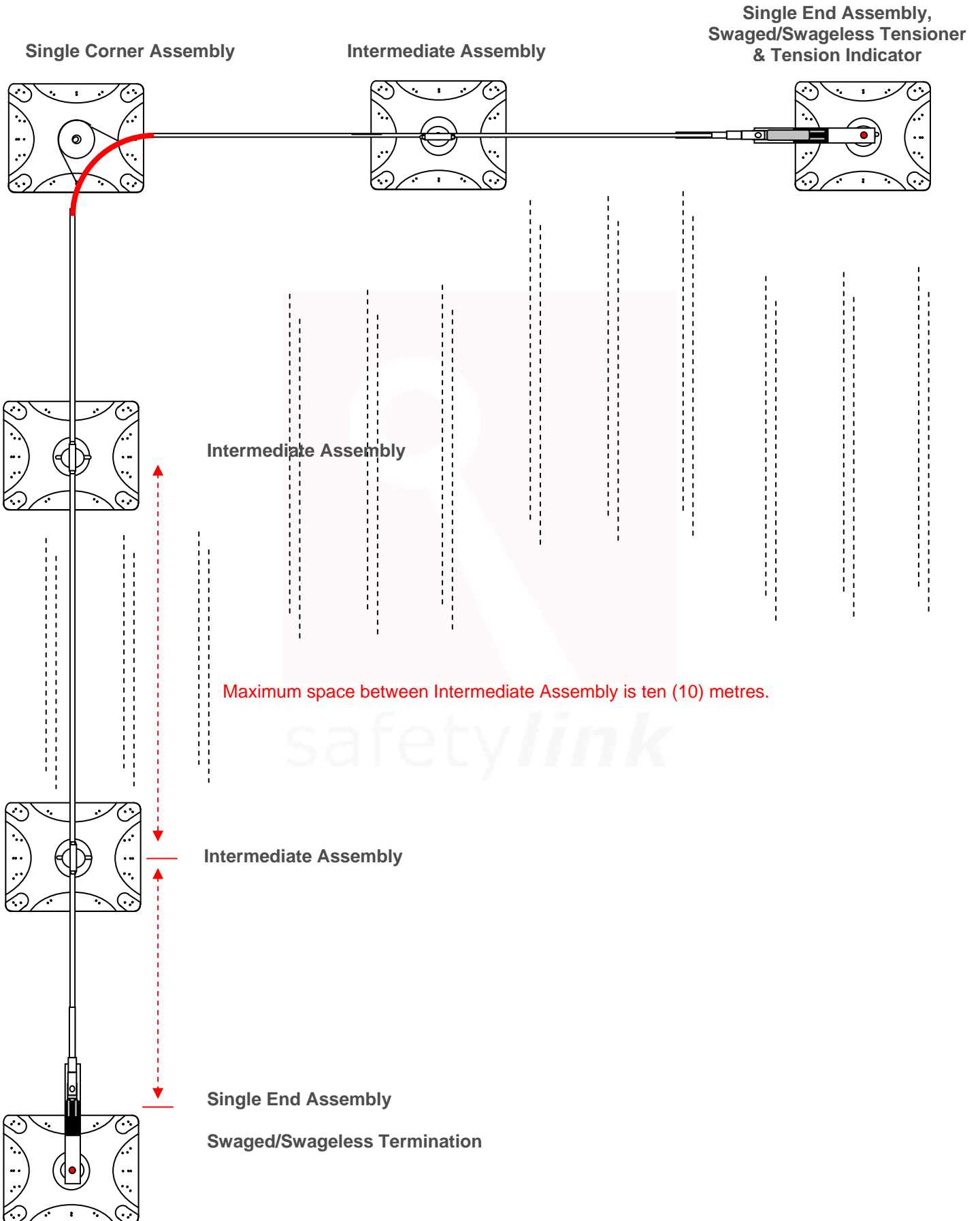





IN CASE OF ACCIDENT

⚠ A FALL RESCUE PLAN SHOULD BE DEVELOPED PRIOR TO USING SAFETYLINK EQUIPMENT.

⚠ Persons working at heights should not work alone.

It is critical that before using any SafetyLink Systems a fall rescue plan is in place for any persons suspended mid-air following a fall. Serious injury or death can occur in a matter of minutes, particularly if a person's movement or breathing is restricted or loss of consciousness has occurred. In accordance with your fall rescue plan and appropriate first aid procedures it is essential to remove the person from the suspended position as quickly as possible.

EQUIPMENT WHICH HAS ARRESTED A FALL OR SHOWS A DEFECT

In accordance with AS/NZS 1891.4:2000 clause 9.5

Any piece of equipment which has been involved in an accident must be withdrawn from service immediately and a replacement obtained if necessary. A label indicating the condition or defect should be attached to the equipment, and it should be examined by a competent person who will decide whether the equipment is to be destroyed or repaired if necessary and returned to service. In the latter case, details of any repair shall be documented and a copy given to the operator.



DISTRIBUTOR:

www.heightsafety.com